

Since 1977



2016 CATALOG

MISSION

We believe, that confidence, satisfaction and quality was required for every Merchant. To trade with peace of mind is your right like everybody. We are with you to offer serve for some brake system parts, which are brake disc, brake drum, axle shaft and wheel hub. and always will continue to be with you. The Company has consistently adhere to equality, reciprocity, mutual benefit, commom development principles, and wish we have a huge improvement together.



Apalı Yılmaz Kardeşler®

QUALITY

CONFIDENCE

SATISFACTION

VISION

We adopt mentality, which can see the future, with continuous updating appearance and equipment fit to the epoch and terms. The placing our company the top ranks of automotive sector has been aimed with the high qualified products, the environmentally sensitive and people-oriented production mentality. Thank you very much in advance because of you have joined to us, that have provided our achievements. We declare that your requirements are our responsibility and obligations.



Apalı Yılmaz Kardeşler®

QUALITY

CONFIDENCE

SATISFACTION

ABOUT AYK

AYK which founded on 1977 in Konya/Turkey has been rapidly updated, as announce its name via the exported high-quality products all over the World and Turkey.

AYK, which catches achievement by adopting principle of the perseverance and the determination, has been proudly serving in the automotive sector nowadays.

We has been manufacturing via superior qualified CNC machines, other equipment's and the experienced personnel in the enclosed and large field. Firstly AYK has been producing Axle Shaft, Brake Disc, Wheel Hub, Brake Drum which was brake system parts of brands of Fiat, Renault, Ford, Peugeot, Citroen Bmc, Nissan, Hyundai, Kia, Mazda, Mitsubishi, Toyota, Lada ETC...

Furthermore, We has been producing any project which you wanted according to drawing sample or Dem, Des, De, lam codes.

We have been progressing with firm steps on branch via exportation all regions of World. AYK had been seeking to gain the satisfaction and confidence of customers with after-sales supports and sensitive and stable stance.

QUALITY

CONFIDENCE

SATISFACTION



T.C.
TÜRK PATENT ENSTİTÜSÜ

MARKA TESCİL BELGESİ

Marka No : 2006 16767 - Hizmet



Apalı Yılmaz Kardeşler

Marka Sahibi : APALI YILMAZ KARDEŞLER
LİMİTED ŞİRKETİ
Fabrika: Büsan Özel Organize San. Sit. Kosgeb Cad.
10647 (7.) Sokak No:16 Karatay / KONYA / TÜRKİYE
Emtiası : 39

Markaların Korunması Hakkında 556 Sayılı Kanun Hükmünde Kararnameye göre 17/04/2006 tarihinden itibaren ON YIL müddetle tescil edilmiştir.

Kutay KUMBASAR
Enstitü Başkanı a.
Markalar Dairesi Başkanı

TÜRK PATENT [] ENSTİTÜSÜ

CERTIFICATE



The Certification Body
of TÜV SÜD/Türkiye

certifies that

APALI YILMAZ KARDEŞLER
LİMİTED ŞİRKETİ

Fabrika: Büsan Özel Organize San. Sit. Kosgeb Cad.
10647 (7.) Sokak No:16 Karatay / KONYA / TÜRKİYE

has established and applies
a Quality Management System for

DESIGN, PRODUCTION AND REFURBISHING OF PRESSURE
VESSELS, BOILERS, CRYOGENIC TANKS AND VAPORIZERS

An audit was performed, Report No: 10 M 20052

Proof has been furnished that the requirements according to

TS EN ISO 9001: 2008
are fulfilled

The certificate is valid until 2013-03-22
if the yearly surveillance audits are performed

Certificate Registration No.: 12 300 0548
Istanbul, 2010-12-07

Please call
0 212 3470810
concerning the certificate



J. Yılmaz
TÜV SÜD Türkiye
System Certification Department



TÜV SÜD / Türkiye • Yıldız Posta Cad. No.17 Kat:5 • TR 34384 Esentepe - İstanbul • Türkiye

TÜV®

TÜRK PATENT [] ENSTİTÜSÜ

QUALITY

CONFIDENCE

SATISFACTION

Since 1977

AYK

Apalı Yılmaz Kardeşler®

Dayanıklı Tüketim Malları San. Tic. Ltd. Şti.
Büsan Özel Organize Sanayi Bölgesi Kosgeb Caddesi 7.
Sokak No: 16 Karatay / KONYA / TÜRKİYE

Tel: +90 332 345 04 56 / Fax : +90 332 345 04 57

www.apalimoto.com

39 YEARS EXPERIENCE

INDEX

001-007...

008-075...

78-129...

134-151...

154-167...

168-202...

INTRODUCTION

WHEEL HUB

BRAKE DRUM

AXLE SHAFT

BRAKE DISC

CRANKSHAFT PULLEY

QUALITY

CONFIDENCE

SATISFACTION

WHEEL HUB GROUP



QUALITY

CONFIDENCE

SATISFACTION

WHEEL HUB GROUP

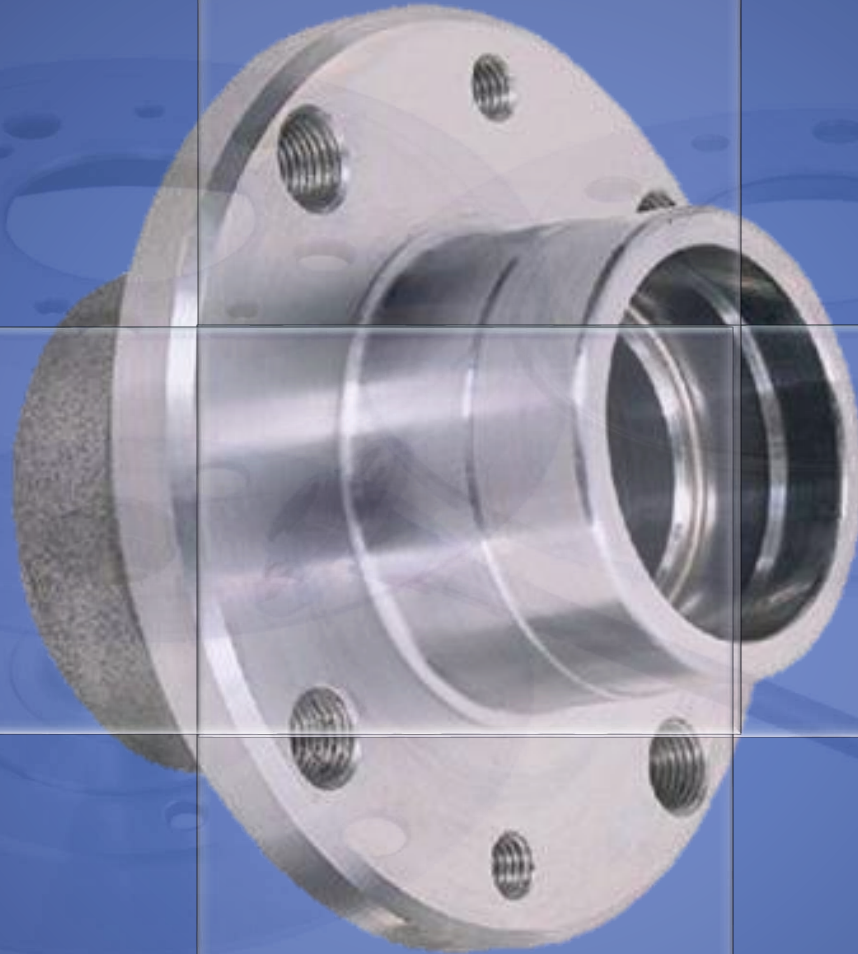

QUALITY

CONFIDENCE

SATISFACTION

Since 1977

AYK

Apalı Yılmaz Kardeşler®

Dayanıklı Tüketim Malları San. Tic. Ltd. Şti.
Büsan Özel Organize Sanayi Bölgesi Kosgeb Caddesi 7.
Sokak No: 16 Karatay / KONYA / TÜRKİYE

Tel: +90 332 345 04 56 / Fax : +90 332 345 04 57

www.apalimoto.com

39 YEARS EXPERIENCE

BRAKE DRUM GROUP



QUALITY

CONFIDENCE

SATISFACTION

BRAKE DRUM GROUP

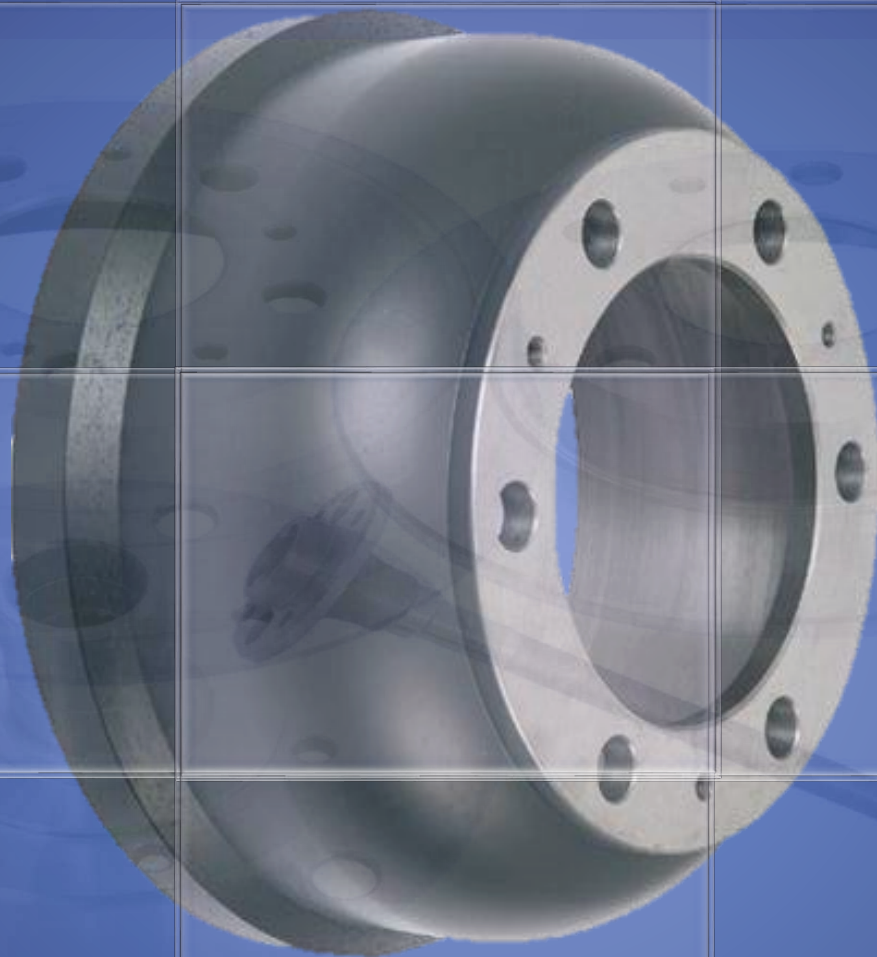

QUALITY

CONFIDENCE

SATISFACTION

3113



BRAND	OEM	ENG	MODEL
RENAULT EXTRA VAN F406, G40A 1239CC	7700304984	1.2	91-98
RENAULT EXTRA VAN F40R 1870CC	7700304984	1.9	94-98
RENAULT KANGOO KC0AKC0K, KC0F, KC01 1149CC	7700304984	1.2	97-14
RENAULT KANGOO KC0C, KC0H KC0B KC0M 1390CC	7700304984	1.4	97-14
RENAULT KANGOO D 55 KC0D 1870	7700304984	1,9	97-14
RENAULT KANGOO D65 KC0E, KC02, KC0J KC0N 1870CC	7700304984	-	97-14
RENAULT KANGOO RAPID FC01, FC0A, FC0F 1149CC	7700304984	1,2	97-14
RENAULT RAPID FC01, FC0A, FC0H, FC0M 1390CC	7700304984	1,4	97-14
RENAULT KANGOO RAPID D55 FC0D 1870CC	7700304984	1.9	97-14
RENAULT KANGOO RAPID D65 FC0E, FC02, FC0J, FC0N 1870CC	7700304984	1.9	97-14
RENAULT KANGOO RAPID DTI KC0U 1870CC	7700304984	1.9	00-14
RENAULT KANGOO DTI FC0U 1870CC	7700304984	1.9	00-14
RENAULT KANGOO 16V 1598CC	7700304984	1.6	01-14
NISSAN	4320000QAF	1.5	01-14
RENAULT KANGOO RAPID DCI FC07, FC1R 1461CC	7700304984	1.5	01-14
RENAULT KANGOO DCI FC08, KC09 1461CC	7700304984	1.5	01-14
RENAULT KANGOO RAPID DCI KC08, KC09 1461CC	7700304984	1.5	01-14
RENAULT KANGOO DCI 1461CC	7700304984	1.9	01-14
RENAULT KANGOO RAPID DCI FC0V 1870CC	7700304984	1.5	02-14

REAR WHEEL BRAKE DRUM



P 82

2058



BRAND	OEM	ENG	MODEL
FORD CONNECT	2T141126DE	-	-
FORD	2T14 1126 CB	-	-
FORD	2T14 1126 CA	-	-
FORD	2T14 1126 CE	-	-
FORD	2T14 1126 DA	-	-
FORD	2T14 1126 DB	-	-
FORD	2T14 1126 DD	-	-
FORD	2T14 1126 DE	-	-
FORD	4367103	-	-
FORD	1361302	-	-
FORD	1361302	-	-
FORD	4367102	-	-
FORD	4467600	-	-
FORD	4455981	-	-
FORD	4937319	-	-
FORD	4937320	-	-

REAR WHEEL BRAKE DRUM



P 90

3111



REAR WHEEL BRAKE DRUM



BRAND	OEM	ENG	MODEL
FIAT FIORINO MULTIJET 1248CC	51816526	1.3 D	09-14
FIAT TIPO HATCHBACK 160AW 1929CC	51816526	1.9 TD	92-93
FIAT	7763353	-	-
FIAT TIPO HATCHBACK 160A1- 160EC-160EB	51816526	1.6 IE	92-95
FIAT	7569600	-	-
FIAT	7769850	-	-
FIAT FIORINO BOX 1697CC	51816526	1.7 D	88-14
ALFA ROMEO	60814839	-	-
ALFA ROMEO	7769850	-	-
FIAT TEMPRA SALOON 159AC- 159AX 1372CC	51816526	1.4 IE	92-96
ALFA ROMEO	60810025	-	-
FIAT TEMPRA SALOON 159AE 1581CC	51816526	1.6 IE	90-92
FIAT TEMPRA SALOON 159AN 1756CC	51816526	1.8 IE	92-96
TEMPRA SW ESTATE 159AQ 1929CC	51816526	1.9 TD	92-93
TEMPRA SW ESTATE 1920CC 159CU-159AU-159AI-159BI	51816526	1.9 TD	91-95
FIAT TEMPRA SW ESTATE 159AC- 159AX 1372CC	51816526	1.4 IE	92-96
FIAT TEMPRA SW ESTATE 159AS- 159AT 1581CC	51816526	1.6 IE	92-96
FIAT TEMPRA SW ESTATE 159AE 1581CC	51816526	1.6 IE	90-96
FIAT TEMPRA SW ESTATE 159AN 1756CC	51816526	1.8 IE	92-93



3036



BRAND	OEM	ENG	MODEL
FORD RANGER	XM341126BA	-	-
FORD	XM341126BC	-	-
FORD	3865373	-	-
FORD	1733773	-	-
MAZDA	UH7426251C	-	-
MAZDA	UH7426251A	-	-
MAZDA B SERIES (UF)	1733773	-	85-99
MAZDA B SERIE (un)	1733773	-	98-06
MAZDA BT-50 (CD, UN)	1733773	-	2006
FORD RANGER (ER, EQ)	1733773	-	98-06
FORD RANGER (ES,ET)	1733773	-	2005
FORD RANGER (TKE)	1733773	-	2011
FORD	XM34 1126 BA	-	-
FORD	XM34 1126 BC	-	-

REAR WHEEL BRAKE DRUM

BRAND	OEM	ENG	MODEL
KIA CERES	ØK68A33251A	2.4	-



2077



BRAND	OEM	ENG	MODEL
KIA CERES 2200	0K67026251	-	-

REAR WHEEL BRAKE DRUM



BRAND	OEM	ENG	MODEL
MITSUBISHI DELICA L032P, L062P) 1597CC	MB193595	1.6	81-86
MITSUBISHI DELICA L032P, L062P 1597CC	MB193595	1.6	84-87
MITSUBISHI DELICA L038P 2347CC	MB193595	2.3D	83-86
MITSUBISHI EXPRESS L300, L032, L062P 1597CC	MB193595	1.6	80-86
MITSUBISHI DELICA P12V, P02V 1598CC	MB193595	1.6	86-94
MITSUBISHI DELICA P05V, P05W, P15V 2477CC	MB193595	2.5	86-14
MITSUBISHI DELICA P02V, P12V 1598CC	MB193595	1.6	86-14
MITSUBISHI DELICA P03V, P13V 1997CC	MB193595	2.0	86-14
MITSUBISHI DELICA P13V, P03W, P13T 1997CC	MB193595	2.0	86-14
MITSUBISHI DELICA P25V, P05W 2477CC	MB193595	2.5D	86-14
MITSUBISHI DELICA P13T, P03W, P03V P13V 1997CC	MB193595	2.0	86-14
MITSUBISHI DELICA P04W, P14V, P04V 2351CC	MB193595	2.4	90-14
MITSUBISHI L300 EXPRESS L038P, L068P 2347CC	MB193595	2.3D	83-86
MITSUBISHI L300 L032P, L062P 1597CC	MB193595	1.6	83-94
MITSUBISHI L300 L039P 2477CC	MB193595	2.5D	86-94
MITSUBISHI L400 1997CC	MB193595	2.0	96-01
MITSUBISHI L400 PB3V, PA3W, PA3V 1997CC	MB193595	2.0	95-02
MITSUBISHI L400 1997CC	MB193595	2.0	96-02





REAR WHEEL BRAKE DRUM

BRAND	OEM	ENG	MODEL
MITSUBISHI TRITON KB4T PICKUP 2477CC	MN102439	2.5DID	05-14
MITSUBISHI TRITON RWD KA4T 2477CC	MN102439	2.5DID	05-14



BRAND	OEM	ENG	MODEL
NISSAN SKY STAR	43206V0300	--	-



2081



BRAND	OEM	ENG	MODEL
KIA CERES	0K68A26251	2.4	-

3103



BRAND	OEM	ENG	MODEL
HYUNDAI ACCENT	5841125010	-	-

REAR WHEEL BRAKE DRUM

3105



BRAND	OEM	ENG	MODEL
TOYOTA HILUX	42431 0K120	-	KUN25
TOYOTA HILUX	42431 0K130	-	KUN35
TOYOTA HILUX	42431 0K140	-	KUN26
TOYOTA HILUX	424310K120	-	TNG26
TOYOTA HILUX	424310K140	-	TNG36

REAR WHEEL BRAKE DRUM



BRAND	OEM	ENG	MODEL
HYUNDAI H10 MINIBUS	52810 4300	-	-
HYUNDAI H100 MNNIBUS DIESEL	528104300	2,5D	94-00
HYUNDAI H100 MINIBUS DIESEL	52810 4300	2,5D	-
KIA	52761 44000	-	-
HYUNDAI H100	52761 44010	-	-



3107



REAR WHEEL BRAKE DRUM

BRAND	OEM	ENG	MODEL
HYUNDAI H200	593294A200	2,5TD	01-14
Hyundai h200	59329 4A200	2.5TD	01-14
HYUNDAI H200 2.5CRDI	59329 4A200	2.5 CRDI	03-14
HYUNDAI STAREX	59329 4A200	2.5 TCI	04-14
HYUNDAI STAREX	59329 4A200	2.5 CRDI	02-14
HYUNDAI STAREX	59329 4A200	2.5 ^{4x4} CRDI	02-14
HYUNDAI H200	59329 4A200	2.5 CRDI	02-14
HYUNDAI H200	59329 4A200	2.5TD 4WD	01-14
HYUNDAI H200	59329 4A200	2.5 CRDI	06-14
HYUNDAI H200	59329 4A200	2.5CRD I4WD	02-14
HYUNDAI H1	59329 4A200	2.5 CRDI	02-14

1077



BRAND	OEM	ENG	MODEL
RENAULT 12	7700302145	-	-
RENAULT DAACIA	7700685473	-	-
RENAULT 9	77007522363	-	-
RENAULT	7700783030	-	-
RENAULT	770014663277	-	-
RENAULT	7700419824	-	-
RENAULT CLIO	7700302145	1.4	-
DACIA	6001548126	1.5	-
LOGAN	6001548126	1.5	-
RENAULT CLIO	7702264257	-	-

REAR WHEEL BRAKE DRUM

BRAND	OEM	ENG	MODEL
FIAT DUCATO	1306211080	2.4	N.M.
FIAT DUCATO	1306211080	2.5	N.M.
ALFA ROMEO	1306211080	-	-
CITROEN	424738	-	-
LANCIA	1306211080	-	-
PEUGEOT	424738	-	-
FIAT	1306211080	-	-



BRAND	OEM	ENG	MODEL
RENAULT KANGOO EXPRESS TDCI	7700421739	1.5	-



AXLE SHAFT GROUP



QUALITY

CONFIDENCE

SATISFACTION

AXLE SHAFT GROUP



QUALITY

CONFIDENCE

SATISFACTION

1123



BRAND	OEM	ENG	MODEL
FORD T15	92MB 4235 GB	-	-
BMC TM 30	4M54086	2500	-
BMC	92MB4235GB	-	-

REAR WHEEL AXLE SHAFT

1138



BRAND	OEM	ENG	MODEL
FORD	86VB 4235 AA	-	-
FORD GERMAN	86VB4235AA	-	-

BRAND	OEM	ENG	MODEL
FORD TAUNUS	AST 4235 A	1.6	-
FORD	AST4235	-	-



2053



BRAND	OEM	ENG	MODEL
FORD V184 DANA DIFRANSIEL	5C16 4235 BD	-	-
FORD	5C164235BD	-	-

2055



BRAND	OEM	ENG	MODEL
FORD V347	6C11 4364 BA	-	-
FORD	6C114364BA	-	-

DOUBLE WHEEL REAR AXLE SHAFT



BRAND	OEM	ENG	MODEL
FORD V184 +ABS	YC15 4234 FB	-	-
FORD	YC154234FB	-	-



BRAND	OEM	ENG	MODEL
FIAT	4472221	-	-
FIAT TOFAŞ LONG 24 SERRATIONS	4472221	1600	-
FIAT	5924548	-	-
FIAT TOFAŞ 26 SERRATIONS	4472221	-	-
FIAT TOFAŞ SHORT	4472221	1600	-



1033



BRAND	OEM	ENG	MODEL
FIAT LANCIA	85014774	-	-
TOFAŞ	85014774	-	-
DOĞAN SLX	85014774	-	N.M.

REAR WHEEL AXLE SHAFT



CRANKSHAFT PULLEY GROUP



QUALITY

CONFIDENCE

SATISFACTION

CRANKSHAFT PULLEY GROUP

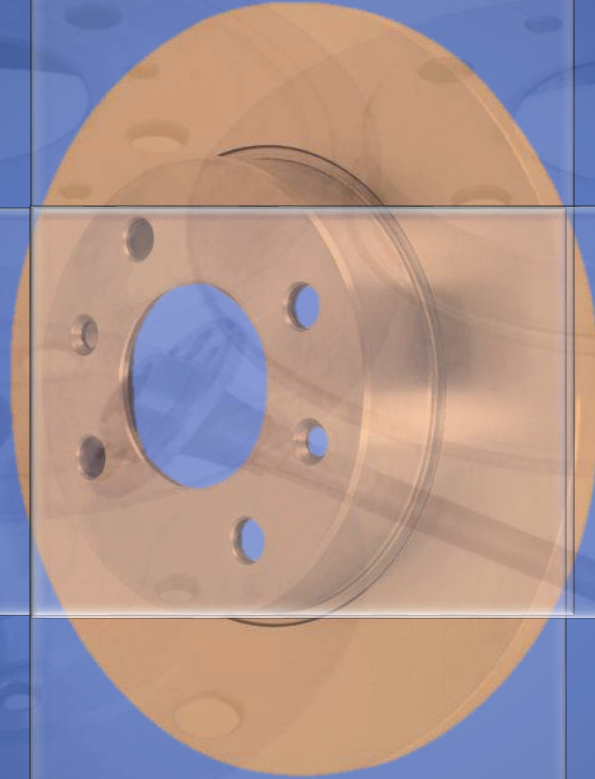

QUALITY

CONFIDENCE

SATISFACTION

1149



BRAND	OEM	ENG	MODEL
BMC 3000 +ABS	57RS302289	-	-

FRONT WHEEL BRAKE DISC

2070



BRAND	OEM	ENG	MODEL
BMC 2500	7M50945	-	-

1201



BRAND	OEM	ENG	MODEL
LADA SAMARA	21083501070	-	-
LADA	21083 501070	-	-

FRONT WHEEL BRAKE DISC

BRAND	OEM	ENG	MODEL
FIAT 128	210135010070	-	-
FIAT NOVA	210135010070	-	-



CRANKSHAFT PULLEY GROUP

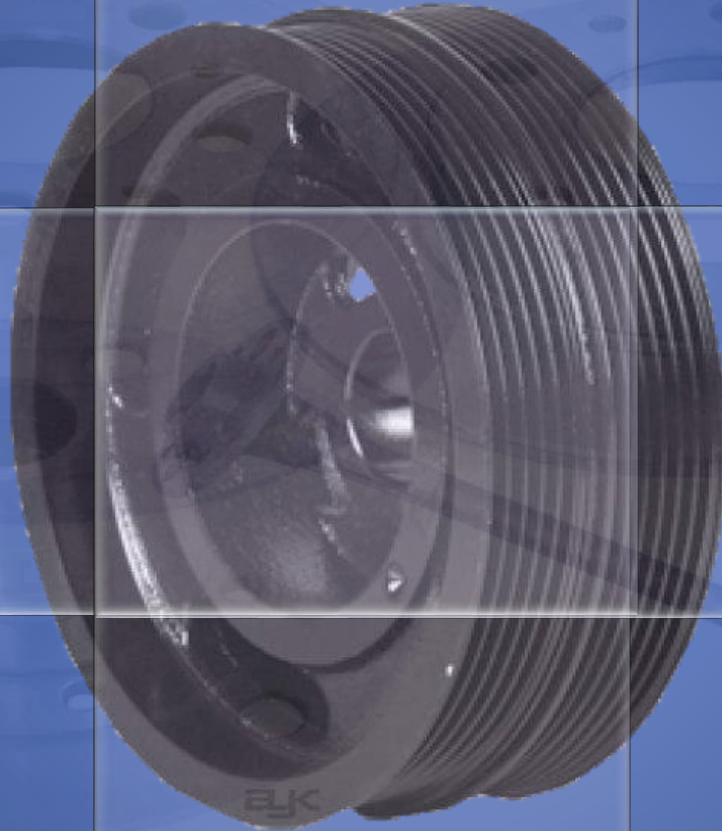

QUALITY

CONFIDENCE

SATISFACTION

CRANKSHAFT PULLEY GROUP

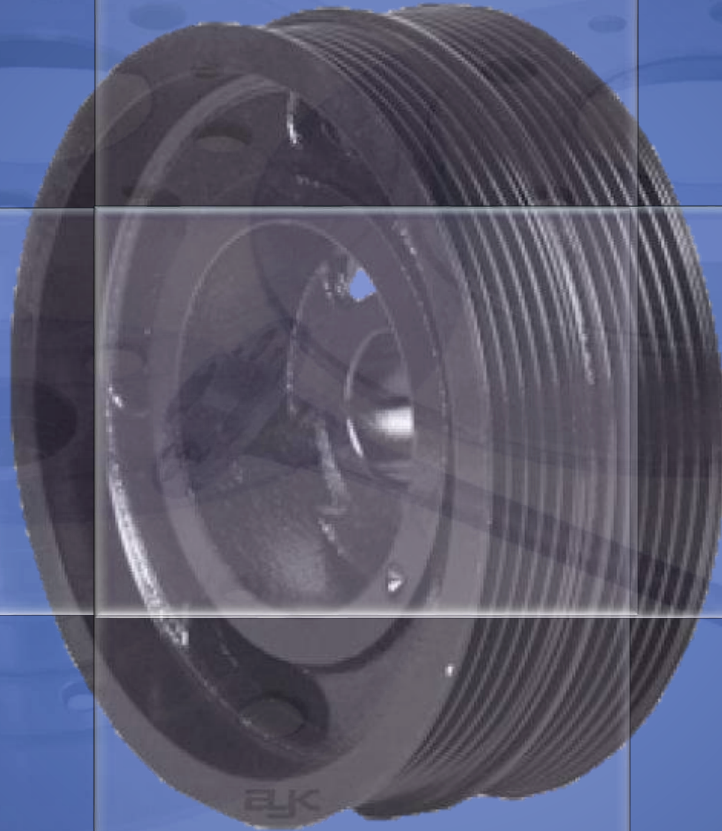

QUALITY

CONFIDENCE

SATISFACTION



ALFA ROMEO
FIAT - LANCIA

Stock No: 5001

Brand	Model	Motorization	Engine	Kw	Hp	Cylinders	Valves	From Date	To Date	Fuel	OEM
ALFA ROMEO	145 (930)	1.9 JTD	AR 32302	77	105	4	2	01.02.1999	01.01.2001	D	46447843
ALFA ROMEO	146 (930)	1.9 JTD	AR 32302	77	105	4	2	01.02.1999	01.01.2001	D	46780491
ALFA ROMEO	147 (937)	1.9 JTD (937AXD1A)	937 A2.000	85	115	4	2	01.04.2001	-	D	46742683
ALFA ROMEO	147 (937)	1.9 JTD 16V	192 A5.000	103	140	4	4	01.11.2002	-	D	55185409
ALFA ROMEO	147 (937)	1.9 JTD 16V	192 B1.000	100	136	4	4	01.10.2004	-	D	55190424
ALFA ROMEO	147 (937)	1.9 JTD 16V	937 A4.000	93	126	4	4	01.09.2003	01.09.2004	D	55196301
ALFA ROMEO	156 (932)	1.9 JTD 16V	192 A5.000	103	140	4	4	01.11.2002	01.09.2005	D	71728496
ALFA ROMEO	159	1.9 JTD 16V	939 A2.000	110	150	4	4	01.09.2005	-	D	71747797
ALFA ROMEO	159	1.9 JTD 8V	939 A1.000	88	120	4	2	01.09.2005	-	D	73501275
ALFA ROMEO	GT	1.9 JTD	937 A5.000	110	150	4	4	01.11.2003	-	D	55196974
FIAT	BRAVO (182)	1.9 JTD 105	182 B4.000	77	105	4	2	01.12.1998	01.10.2001	D	55208280
FIAT	BRAVO (182)	1.9 JTD 105	182 B4.000	77	105	4	2	01.12.1998	01.10.2001	D	
FIAT	CROMA (194)	1.9 D Multijet	939 A1.000	88	120	4	2	01.06.2005	-	D	
FIAT	CROMA (194)	1.9 D Multijet	939 A2.000	110	150	4	4	01.06.2005	-	D	
FIAT	DOBLO (119)	1.9 D (223AXB1A)	223 A6.000	46	63	4	2	01.03.2001	-	D	
FIAT	DOBLO (119)	1.9 JTD	223 A7.000	77	105	4	2	01.07.2003	-	D	
FIAT	DOBLO (119)	1.9 JTD (223AXE1A)	182 B9.000	74	100	4	2	01.10.2001	-	D	
FIAT	GRANDE PUNTO(199)	1.9 D Multijet	199 A5.000	96	130	4	2	01.10.2005	-	D	
FIAT	GRANDE PUNTO(199)	1.9 D Multijet	939 A1.000	88	120	4	2	01.10.2005	-	D	
FIAT	IDEA	1.9 JTD	188 B2.000	74	101	4	2	01.01.2004	-	D	
FIAT	MAREA (185)	1.9 JTD 105	182 B4.000	77	105	4	2	01.04.1999	01.01.2001	D	
FIAT	MAREA (185)	1.9 JTD 110	185 A6.000	81	110	4	2	01.01.2001	-	D	
FIAT	MAREA (185)	1.9 TD 75	182 A8.000	55	75	4	2	01.09.1996	-	D	
FIAT	MULTIPLA (186)	1.9 JTD (185AXE1A)	185A9.000	88	120	4	2	01.04.2002	-	D	
FIAT	MULTIPLA (186)	1.9 JTD 105 (186AXB1A)	182 B4.000	77	105	4	2	01.04.1999	-	D	
FIAT	MULTIPLA (186)	1.9 JTD 110	185 A6.000	81	110	4	2	01.03.2001	01.07.2002	D	
FIAT	PALIO (178BX)	1.9 D	223 A6.000	46	63	4	2	01.09.2000	-	D	
FIAT	PALIO Weekend (178DX)	1.9 JTD	188 A2.000	59	80	4	2	01.09.2001	-	D	
FIAT	SEDICI	1.9 D Multijet	D19AA	88	120	4	2	01.06.2006	-	D	
FIAT	STILO (192)	1.9 D Multijet	192 A8.000	88	120	4	2	01.09.2005	-	D	
FIAT	STILO (192)	1.9 D Multijet	937 A5.000	110	150	4	4	01.09.2005	-	D	
FIAT	STILO (192)	1.9 JTD (192_XF1A)	192 A3.000	59	80	4	2	01.02.2002	-	D	
LANCIA	LYBRA (839AX)	1.9 JTD (839AXD1A)	AR 32302	77	105	4	2	01.07.1999	01.09.2000	D	
LANCIA	LYBRA (839AX)	1.9 JTD (839AX1A)	AR 37101	81	110	4	2	01.09.2000	01.05.2001	D	
LANCIA	MUSA (350)	1.9 D Multijet	188 B2.000	74	101	4	2	01.10.2004	-	D	



ALFA ROMEO
FIAT - LANCIA

Stock No: 5002

Brand	Model	Motorization	Engine	Kw	Hp	Cylinders	Valves	From Date	To Date	Fuel	OEM
FIAT	DOBLO (119)	1.9 D (223AXB1A)	223 A6.000	46	63	4	2	01.03.2001	-	D	46770939
FIAT	DOBLO Cargo (223)	1.9 D (223XB1A)	223 A6.000	46	63	4	2	01.03.2001	-	D	46809686
FIAT	PALIO Weekend (178DX)	1.9 D (178DYD1A07)	223 A6.000	46	63	4	2	01.03.2001	-	D	55190581
FIAT	PUNTO (188)	1.9 DS 80 (188.031, .051, .231, .251)	188 A3.000	44	60	4	2	01.09.1999	-	D	
FIAT	PUNTO Van (188AX)	1.9 D 60	188 A3.000	44	60	4	2	01.02.2000	-	D	



Stock No: 5003

Brand	Model	Motorization	Engine	Kw	Hp	Cylinders	Valves	From Date	To Date	Fuel	OEM
FIAT	DUCATO Box (230L)	2.0 JTD	RHV (DW10)	62	84	4	2	01.10.2001	01.04.2002	D	9641548980
FIAT	DUCATO Bus (230)	2.0 JTD	RHV (DW10)	62	84	4	2	01.10.2001	01.04.2002	D	9681761480
FIAT	SCUDO Box (220L)	2.0 JTD	RHX	69	94	4	2	01.12.1999	-	D	9467597180
FIAT	SCUDO Box (220L)	2.0 JTD	RHZ	80	109	4	2	01.12.2002	-	D	9467586180
FIAT	SCUDO Combinato (220P)	2.0 JTD	RHX	69	94	4	2	01.01.2004	-	D	
FIAT	SCUDO Combinato (220P)	2.0 JTD	RHZ	80	109	4	2	01.12.1999	-	D	
FIAT	ULYSSE (179AX)	2.0 JTD	RHW(DW10ATED4)	90	109	4	4	01.08.2002	-	D	
FIAT	ULYSSE (179AX)	2.2 JTD	4HW(DW12ATED4)	94	128	4	4	01.08.2002	-	D	
FIAT	ULYSSE (220)	2.0 JTD	RHZ	80	109	4	2	01.10.1999	01.08.2002	D	
LANCIA	PHEDRA (179)	2.0 JTD (179AXB1A)	RHW(DW10ATED4)	80	109	4	4	01.09.2002	-	D	
LANCIA	PHEDRA (179)	2.2 JTD (179AXC1A)	4HW(DW12ATED4)	94	128	4	4	01.09.2002	-	D	
LANCIA	ZETA (220)	2.0 JTD (220ANS)	RHW	80	109	4	4	01.09.1999	01.09.2002	D	



ALFA ROMEO
FIAT - LANCIA

Stock No: 5004

Brand	Model	Motorization	Engine	Kw	Hp	Cylinders	Valves	From Date	To Date	Fuel	OEM
FIAT	ULYSSE (220)	1.8	LFV	73	99	4		01.05.1997	01.08.2002	F	9517691980



Stock No: 5005

Brand	Model	Motorization	Engine	Kw	Hp	Cylinders	Valves	From Date	To Date	Fuel	OEM
FIAT	SCUDO Box (220L)	1.9 D	WJZ (DW8)	51	69	4	2	01.04.1998	-	D	0515L7 0515Q6 9537219880 9524595880



Stock No: 3031

Brand	Model	Motorization	Engine	Kw	Hp	Cylinders	Valves	From Date	To Date	Fuel	OEM
FIAT	DUCATO Bus (250)	100 Multijet 2.2 D	4HV	74	100	4	4	01.07.2006	-	D	9559920090



ALFA ROMEO
FIAT - LANCIA

Stock No: 5006

Brand	Model	Motorization	Engine	Kw	Hp	Cylinders	Valves	From Date	To Date	Fuel	OEM
FIAT	DUCATO Box (244)	2.3 JTD	F1AE0481C	81	110	4	4	01.04.2002	-	D	504017415
FIAT	DUCATO Bus (244, T_)	2.3 JTD	F1AE0481C	81	110	4	4	01.04.2002	-	D	504078435
FIAT	DUCATO Flatbed / Chassis (244)	2.3 JTD	F1AE0481C	81	110	4	4	01.04.2002	-	D	
IVECO	DAIL II Box Body / Estate	29 L 10 V	F1AE0481A	70	95	4	4	01.09.2002	-	D	
IVECO	DAIL II Box Body / Estate	35 S 10	F1AE0481A	70	95	4	4	01.09.2002	-	D	
IVECO	DAIL II Platform / Chassis	29 L 10	F1AE0481A	70	95	4	4	01.09.2002	-	D	
IVECO	DAIL II Platform / Chassis	35 C 10 V, 35S 10 V	F1AE0481A	70	95	4	4	01.09.2002	-	D	
IVECO	DAIL III Box Body / Estate	35C10,35S10	F1AE0481FA	70	95	4	4	01.05.2006	-	D	



Stock No: 5007

Brand	Model	Motorization	Engine	Kw	Hp	Cylinders	Valves	From Date	To Date	Fuel	OEM
FIAT	BRAVO (182)	1.2 16V 80	182 B2.000	60	82	4	4	01.12.1998	01.10.2000	P	7778028
FIAT	BRAVO (182)	1.2 16V 80	182 B2.000	60	82	4	4	01.12.1998	01.10.2000	P	
FIAT	DOBLO (119)	1.2 (223AXA1A)	223 A5.000	48	65	4	2	01.03.2001	-	P	
FIAT	DOBLO Cargo (223)	1.2 (223DXA1A)	223 A5.000	48	65	4	2	01.03.2001	-	P	
FIAT	PALIO Weekend (178DX)	1.2 (178DX.G1A)	178 B5.000	54	73	4	2	01.04.1996	01.02.2001	P	
FIAT	PUNTO (176)	60 1.2	176 A7.000	43	58	4	2	01.01.1994	01.09.1999	P	
FIAT	PUNTO (176)	75 1.2	176 A8.000	54	73	4	2	01.10.1993	01.09.1999	P	
FIAT	PUNTO (176)	85 16V 1.2	176 B9.000	63	86	4	4	01.04.1997	01.09.1999	P	
FIAT	PUNTO Convertible (176C)	60 1.2	176 A7.000	43	58	4	2	01.04.1994	01.06.2000	P	
FIAT	STRADA (178E)	12	178 B5.000	54	73	4	2	01.05.1999	-	P	
LANCIA	Y (840A)	1.2 (840AA)	188 A4.000	44	60	4	2	01.03.1996	01.09.2003	P	
LANCIA	Y (840A)	1.2 16V (840AD)	176 B9.000	63	86	4	4	01.04.1997	01.09.2003	P	
LANCIA	Y (840A)	1.2 16V (840AG1A)	188 A5.000	59	80	4	4	01.10.2000	01.09.2003	P	



ALFA ROMEO
FIAT - LANCIA

ALFA ROMEO
FIAT - LANCIA

Stock No: 5008

Brand	Model	Motorization	Engine	Kw	Hp	Cylinders	Valves	From Date	To Date	Fuel	OEM
FIAT	GRANDE PUNTO (199)	1.3 D Multijet	199 A2.000	55	75	4	4	01.10.2005	-	D	46819147
FIAT	GRANDE PUNTO (199)	1.3 D Multijet	199 A3.000	66	90	4	4	01.10.2005	-	D	55200498
FIAT	IDEA	1.3 D Multijet	199 A3.000	66	90	4	4	01.10.2005	-	D	
FIAT	IDEA	1.3 JTD	188 A9.000	51	70	4	4	01.01.2004	-	D	
FIAT	PANDA (169)	1.3 D Multijet	188 A9.000	51	70	4	4	01.06.2003	-	D	
FIAT	PUNTO (185)	1.3 JTD 16V	188 A9.000	51	70	4	4	01.06.2003	-	D	
LANCIA	MUSA (350)	1.3 D Multijet	188 A9.000	51	70	4	4	01.10.2004	-	D	
LANCIA	YPSILON (843)	1.3 JTD	188 A9.000	51	70	4	4	01.10.2003	-	D	

Stock No: 5010

Brand	Model	Motorization	Engine	Kw	Hp	Cylinders	Valves	From Date	To Date	Fuel	OEM
FIAT	DOBLO (119)	1.3 D Multijet	223 A9.000	62	84	4	4	01.10.2005	-	D	55182505
FIAT	DOBLO (119)	1.3 JTD	199 A2.000	55	75	4	4	01.05.2005	-	D	55182509
FIAT	DOBLO Cargo (223)	1.3 D Multijet	199 A2.000	55	75	4	4	01.10.2005	-	D	
FIAT	DOBLO Cargo (223)	1.3 JTD 16V	188 A9.000	51	70	4	4	01.05.2004	-	D	
FIAT	FIORINO Box	1.3 D Multijet	199 A2.000	55	75	4	4	01.02.2008	-	D	
FIAT	LINEA	1.3 D Multijet	199 A3.000	66	90	4	4	01.06.2007	-	D	
FIAT	PALIO (176BX)	1.3 JTD Multijet	188 A9.000	51	69	4	4	01.06.2003	-	D	



Stock No: 5009

Brand	Model	Motorization	Engine	Kw	Hp	Cylinders	Valves	From Date	To Date	Fuel	OEM
FIAT	DUCATO Box (230L)	2.8 JTD	8140.436	94	128	4	2	01.11.2000	01.04.2002	D	5000312310
FIAT	DUCATO Box (230L)	2.8 JTD 4x4	8140.436	94	128	4	2	01.11.2000	01.04.2002	D	500332292
FIAT	DUCATO Box (244)	2.8 JTD	8140.436	94	128	4	2	01.04.2002	-	D	99461230
FIAT	DUCATO Box (244)	2.8 JTD 4x4	8140.436	94	128	4	2	01.07.2002	-	D	
FIAT	DUCATO Bus (230)	2.8 JTD	8140.436	94	128	4	2	01.11.2000	01.04.2002	D	
FIAT	DUCATO Bus (230)	2.8 JTD 4x4	8140.436	94	128	4	2	01.11.2000	01.04.2002	D	
FIAT	DUCATO Bus (244_Z_)	2.8 JTD	8140.436	94	128	4	2	01.04.2002	-	D	
FIAT	DUCATO Bus (244_Z_)	2.8 JTD 4x4	8140.436	94	128	4	2	01.07.2002	-	D	
FIAT	DUCATO Flatbed / Chassis (230)	2.8 JTD	8140.436	94	128	4	2	01.11.2000	01.04.2002	D	
FIAT	DUCATO Flatbed / Chassis (244)	2.8 JTD	8140.436	94	128	4	2	01.04.2002	-	D	
FIAT	DUCATO Flatbed / Chassis (244)	2.8 JTD 4x4	8140.436	94	128	4	2	01.10.2002	-	D	

Stock No: 5011

Brand	Model	Motorization	Engine	Kw	Hp	Cylinders	Valves	From Date	To Date	Fuel	OEM
FIAT	DUCATO Box (230L)	1.9 D	DJY	50	68	4	2	01.04.1998	01.04.2002	D	9608938980
FIAT	DUCATO Box (230L)	1.9 TD	DHX	66	90	4	2	01.04.1998	01.04.2002	D	
FIAT	SCUDO Box (220L)	1.9 D	D9B	51	69	4	2	01.02.1996	-	D	
FIAT	SCUDO Box (220L)	1.9 TD	DHX	66	90	4	2	01.02.1996	-	D	
FIAT	ULYSSE (220)	1.9 TD (220 AH5)	DHX	66	90	4	2	01.02.1995	01.08.2002	D	



ALFA ROMEO
FIAT - LANCIA

ALFA ROMEO
FIAT - LANCIA

Stock No: 5012

Brand	Model	Motorization	Engine	Kw	Hp	Cylinders	Valves	From Date	To Date	Fuel	OEM
FIAT	SCUDO Box (220L)	2.0 JTD	RHX	69	94	4	2	01.12.1999	-	D	9467510480
FIAT	SCUDO Box (220L)	2.0 JTD	RHZ	80	109	4	2	01.12.2002	-	D	9630647280
FIAT	SCUDO Combinato (220F)	2.0 JTD	RHX	69	94	4	2	01.01.2004	-	D	9651770980
FIAT	SCUDO Combinato (220F)	2.0 JTD	RHZ	80	109	4	2	01.12.1999	-	D	
FIAT	ULYSSE (179AX)	2.0 JTD	RHW	80	109	4	4	01.08.2002	-	D	
FIAT	ULYSSE (179AX)	2.2 JTD	4HW	94	128	4	4	01.08.2002	-	D	
LANCIA	PHEORA (179)	2.0 JTD (179AXB1A)	RHW	80	109	4	4	01.09.2002	-	D	
LANCIA	PHEORA (179)	2.2 JTD (179AXC1A)	4HW	94	128	4	4	01.09.2002	-	D	

Stock No: 5013

Brand	Model	Motorization	Engine	Kw	Hp	Cylinders	Valves	From Date	To Date	Fuel	OEM
ALFA ROMEO	145 (930)	2.0 16V Quadrifoglio	AR 32301	114	155	4	4	01.03.1998	01.01.2001	F	55189083
ALFA ROMEO	145 (930)	2.0 16V Quadrifoglio	AR 32301	114	155	4	4	01.03.1998	01.01.2001	F	60630428
ALFA ROMEO	147 (937)	1.6 16V T.SPARK (937AXB1A)	AR 32104	88	120	4	4	01.01.2001	-	F	60815976
ALFA ROMEO	147 (937)	1.6 16V T.SPARK ECO (937AXA1A)	AR 37203	77	105	4	4	01.01.2001	-	F	
ALFA ROMEO	147 (937)	2.0 16V T.SPARK (937AXC1_)	AR 32310	110	150	4	4	01.01.2001	-	F	
ALFA ROMEO	155 (932)	1.5 16V T.SPARK (932A4)	AR 32102	88	120	4	4	01.09.1997	01.09.2005	F	
ALFA ROMEO	155 (932)	1.8 16V T.SPARK (932A3)	AR 32201	105	144	4	4	01.09.1997	01.10.2000	F	
ALFA ROMEO	155 (932)	1.8 16V T.SPARK (932A31_)	AR 32205	103	140	4	4	01.10.2000	01.09.2005	F	
ALFA ROMEO	155 (932)	2.0 16V T.SPARK (932A2)	AR 32301	114	155	4	4	01.09.1997	01.10.2000	F	
ALFA ROMEO	155 (932)	2.0 JTS (932AX4)	937 A1.000	122	166	4	4	01.03.2002	01.09.2005	F	
ALFA ROMEO	156 Sportwagon (932)	1.5 16V T.SPARK (932A4)	AR 32102	88	120	4	4	01.05.2000	01.05.2006	F	
ALFA ROMEO	156 Sportwagon (932)	1.8 16V T.SPARK (932A3)	AR 32201	105	144	4	4	01.05.2000	01.10.2000	F	
ALFA ROMEO	156 Sportwagon (932)	1.8 16V T.SPARK (932B31_)	AR 32205	103	140	4	4	01.10.2000	01.05.2006	F	
ALFA ROMEO	156 Sportwagon (932)	2.0 16V T.SPARK (932A2)	AR 32301	114	155	4	4	01.05.2000	01.10.2000	F	
ALFA ROMEO	156 Sportwagon (932)	2.0 JTS (932BX4)	937 A1.000	122	166	4	4	01.03.2002	01.05.2006	F	
ALFA ROMEO	166 (936)	2.0 T.spark (936A3A_)	AR 34103	114	155	4	4	01.09.1998	01.10.2000	F	
ALFA ROMEO	166 (936)	2.0 T.spark (936A3B_)	AR 36301	110	150	4	4	01.10.2000	-	F	
ALFA ROMEO	GTV (916C_)	1.8 16V (916C3)	AR 32201	105	144	4	4	01.05.1998	-	F	
ALFA ROMEO	GTV (916C_)	2.0 T.SPARK 16V (916C2C)	AR 32301	114	155	4	4	01.05.1998	01.08.2000	F	
ALFA ROMEO	SPIDER (916S_)	1.8 16V (916S3)	AR 32201	105	144	4	4	01.05.1998	01.04.2005	F	
ALFA ROMEO	SPIDER (916S_)	2.0 T.SPARK 16V (916S2B)	AR 32301	114	155	4	4	01.05.1998	01.08.2000	F	
FIAT	BARCETTA (183)	1.8 16V	183 A1.000	96	130	4	4	01.04.1995	-	F	
FIAT	BRAVO (182)	1.8 GT 16V (182.BC)	182 A2.000	83	113	4	4	01.10.1995	01.10.2001	F	
FIAT	COUPE (FA/175)	1.8 16V	183 A1.000	96	131	4	4	01.03.1995	01.08.2000	F	
FIAT	MAREA (185)	1.8 115 16V	182 A2.000	83	113	4	4	01.09.1995	-	F	
FIAT	MAREA Weekend (185)	1.8 115 16V	182 A2.000	83	113	4	4	01.09.1995	-	F	
FIAT	FUNTO (188)	1.8 130 HGT (188.736_718)	183 A1.000	96	130	4	4	01.09.1999	-	F	
FIAT	STILO (192)	1.8 16V (192_XC1A)	192 A4.000	98	133	4	4	01.10.2001	-	F	
FIAT	STILO Mult Wagon (192)	1.8 16V	192 A4.000	98	133	4	4	01.01.2003	-	F	
LANCIA	DELTA II (835)	1.8 i.e. 16V GT (835AR)	183 A1.000	96	131	4	4	01.03.1995	01.08.1999	F	
LANCIA	LYBRA (839AX)	1.8 16V (839AXB1A, 839AX-G1A)	839 A4.000	96	131	4	4	01.07.1999	-	F	
LANCIA	LYBRA SW (839BX)	1.8 16V (839BXB1A, 839BX-G1A)	839 A4.000	96	131	4	4	01.07.1999	-	F	



Stock No: 5014

Brand	Model	Motorization	Engine	Kw	Hp	Cylinders	Valves	From Date	To Date	Fuel	OEM
FIAT	ULYSSE (179AX)	2.0 0 Multijet	RHX	88	120	4	4	01.05.2005	-	D	9643354180
FIAT	ULYSSE (179AX)	2.0 0 Multijet	RHR	100	136	4	4	01.05.2005	-	D	9658659580
LANCIA	PHEORA (179)	2.0 JTD	RHX	88	120	4	4	01.05.2005	-	D	9661640880



FORD

FORD

Stock No: 5015

Stock No: 3025

Brand	Model	Motorization	Engine	Kw	Hp	Cylinders	Valves	From Date	To Date	Fuel	OEM
FORD	GALAXY (WGR)	1.9 TDI	ASZ	96	130	4	2	01.02.2003	01.05.2006	D	1315782
FORD	GALAXY (WGR)	1.9 TDI	AUY	85	115	4	2	01.04.2000	01.05.2006	D	3M216B320AA
FORD	GALAXY (WGR)	1.9 TDI	BTB	110	150	4	2	01.05.2006	01.05.2006	D	

Brand	Model	Motorization	Engine	Kw	Hp	Cylinders	Valves	From Date	To Date	Fuel	OEM
FORD	MONDEO II (BSY)	2.0 TDCI	FMBA	96	130	4	4	1.10.2001	1.8.2007	D	1124891
FORD	TRANSIT Box (FA_)	2.0 DI (FAE_ FAF_ FAG_)	ABFA	74	100	4	2	1.8.2000	1.5.2006	D	1151394
FORD	TRANSIT Box (FA_)	2.0 TDCI	FIFA	92	125	4	4	1.8.2002	01.05.2006	D	1226637
											1351731
											1226638
											1329203
											1349993
											1594953
											4C1Q6B319DB
											197Q6B319AB
											107Q6B319AC
											197Q6B319BA
											197Q6B319BB
											4C1Q6B319C1A
											4C1Q6B319C1B
											4C1Q6B319DC



Stock No: 3023

Stock No: 3026

Brand	Model	Motorization	Engine	Kw	Hp	Cylinders	Valves	From Date	To Date	Fuel	OEM
FORD	TRANSIT	3.2 TDCI 200 BEYGR								D	7C166B319AA 7C166B319AB

Brand	Model	Motorization	Engine	Kw	Hp	Cylinders	Valves	From Date	To Date	Fuel	OEM
FORD	FIESTA	1.4 TDCI		68	4	4		1.11.2001			1147683
FORD	FIESTA	1.6 TDCI		90	4	4		1.11.2004			1319618
FORD	FOCUS C MAX	1.6 TDCI		109	4	4		1.10.2003	01.03.2007		1319619
FORD	FOCUS II	1.6 TDCI		109	4	4		1.11.2004			1369546
FORD	FOCUS III	1.6 TDCI		109	4	4		1.11.2004			3M5Q6B319CC
FORD	FUSION	1.4 TDCI		68	4	4		1.8.2002			3M5Q6B319CB
FORD	FUSION	1.6 TDCI		90	4	4		1.11.2004			266Q6B319AA



Stock No: 3024

Brand	Model	Motorization	Engine	Kw	Hp	Cylinders	Valves	From Date	To Date	Fuel	OEM
FORD	TRANSIT Box	2.4 TDCI	H9FD	103	140	4	4	01.07.2006	-	D	1379796
FORD	TRANSIT Box	2.4 TDCI	JXFA	85	115	4	4	01.07.2006	-	D	6C1Q6B319EA
FORD	TRANSIT Box	2.4 TDCI	PHFA	74	100	4	4	01.07.2006	-	D	BK3Q6B319CA
FORD	TRANSIT Bus	2.4 TDCI	H9FB	103	140	4	4	01.07.2006	-	D	BK3Q6B319CB
FORD	TRANSIT Bus	2.4 TDCI	JXFA	85	115	4	4	01.07.2006	-	D	1727140
FORD	TRANSIT Bus	2.4 TDCI	PHFA	74	100	4	4	01.07.2006	-	D	1788942



FORD

FORD

Stock No: 3027

Stock No: 5079

Brand	Model	Motorization	Engine	Kw	Hp	Cylinders	Valves	From Date	To Date	Fuel	OEM
FORD	FIESTA V (JH_, JO_)	1.4 TDCI	F6JA	50	68	4	2	01.11.2001	-	D	1147683
FORD	FIESTA V (JH_, JO_)	1.6 TDCI	HHJA	66	90	4	4	01.11.2004	-	D	1319518
FORD	FOCUS C-MAX	1.6 TDCI	G8DA	80	109	4	4	01.10.2003	01.03.2007	D	1319519
FORD	FOCUS II (DA_)	1.6 TDCI	G8DA	80	109	4	4	01.11.2004	-	D	1369546
FORD	FOCUS II Turnier (DAW_)	1.6 TDCI	G8DA	80	109	4	4	01.11.2004	-	D	3MSQ68319CC
FORD	FUSION (JU_)	1.4 TDCI	F6JA	50	68	4	2	01.08.2002	-	D	3MSQ68319CS
FORD	FUSION (JU_)	1.6 TDCI	HHJA	66	90	4	4	01.11.2004	-	D	2S5Q68319AA

/AB /AD

Brand	Model	Motorization	Engine	Kw	Hp	Cylinders	Valves	From Date	To Date	Fuel	OEM
FORD	FOCUS (DAW, DBW)	1.8 TDCI	F9DA	85	115	4	2	1.3.2001	1.11.2004	D	1143413
FORD	FOCUS (DAW, DBW)	1.8 TDCI	FFDA	74	100	4	2	1.9.2002	1.11.2004	D	1151392
FORD	FOCUS Estate (DNW)	1.8 TDCI	F9DA	85	115	4	2	1.3.2001	1.11.2004	D	134Q68319AE
FORD	FOCUS Estate (DNW)	1.8 TDCI	FFDA	74	100	4	2	1.9.2002	1.11.2004	D	134Q68319AF
FORD	FOCUS Saloon (DFW)	1.8 TDCI	F9DA	85	115	4	2	1.3.2001	1.11.2004	D	
FORD	FOCUS Saloon (DFW)	1.8 TDCI	FFDA	74	100	4	2	1.9.2002	1.11.2004	D	
FORD	GALAXY	1.8 TDCI	FPWA	74	100	4	2	1.5.2006	-	D	
FORD	GALAXY	1.8 TDCI	QYWA	92	125	4	4	1.5.2006	-	D	
FORD	MONDEO IV	1.8 TDCI	FPBA	74	100	4	4	1.3.2007	-	D	
FORD	MONDEO IV Turnier	1.8 TDCI	FPBA	74	100	4	4	1.3.2007	-	D	
FORD	S-MAX	1.8 TDCI	QYWA	92	125	4	4	1.5.2006	-	D	

Stock No: 5018



Brand	Model	Motorization	Engine	Kw	Hp	Cylinders	Valves	From Date	To Date	Fuel	OEM
FORD	GALAXY (WGR)	1.9 TDI	12	66	90	4	2	01.03.1998	01.05.2006	D	7198528
FORD	GALAXY (WGR)	1.9 TDI	APN	81	110	4	2	01.08.1997	01.04.2000	D	1069593

96VW68321CB

96VW68321CA



Stock No: 3029

Stock No: 5008



Brand	Model	Motorization	Engine	Kw	Hp	Cylinders	Valves	From Date	To Date	Fuel	OEM
FORD	C-MAX	1.8 TDCI	KKDA	85	115	4	4	01.02.2007	-	D	132Q68319BA (132Q68319BA)
FORD	FOCUS C-MAX	1.8 TDCI	KKDA	85	115	4	4	1.1.2005	1.3.2007	D	4MSQ68319BA
FORD	FOCUS II (DA_)	1.8 TDCI	KKDA	85	115	4	4	1.1.2005	-	D	134Q68319BD
FORD	GALAXY	1.8 TDCI	FPWA	74	100	4	2	1.5.2006	-	D	2MSQ68319AA

Brand	Model	Motorization	Engine	Kw	Hp	Cylinders	Valves	From Date	To Date	Fuel	OEM
FORD	KA	1.8 TDCI		55	75	4		1.2.2009		D	1564852

96S168319AA



FORD

FORD

Stock No: 5014

Stock No: 3030

Brand	Model	Motorization	Engine	Kw	Hp	Cylinders	Valves	From Date	To Date	Fuel	OEM
FORD	FOCUS C-MAX	2.0 TDCI	G6DA, G6DB, G6DD	100	136	4		1.10.2003	1.3.2007	D	1231959
FORD	C-MAX	2.0 TDCI		100	136	4		1.2.2007		D	1490842
FORD	FOCUS II (DA_)	2.0 TDCI		100	136	4		1.11.2004		D	1520590
FORD	FOCUS II STUFENHECK (DA_)	2.0 TDCI		81	110	4		1.4.2005		D	3MSQ68319AA
FORD	FOCUS II TURNIER (DAW_)	2.0 TDCI		81	110	4		1.11.2004		D	7MSQ68319AA
FORD	FOCUS II CABRIOLET	2.0 TDCI	G6DA, G6DB, G6DD	100	136	4		1.10.2006		D	7MSQ68319AB
FORD	GALAXY	2.0 TDCI	AZWA	96	130	4		1.5.2006		D	
FORD	KUGA	2.0 TDCI		100	136	4		1.3.2006		D	
FORD	MONDEO IV	2.0 TDCI	KLBA, LPBA	85	115	4		1.3.2007		D	
FORD	MONDEO IV STUFENHECK	2.0 TDCI	N78B, AZBA	96	130	4		1.3.2007		D	
FORD	MONDEO IV TURNIER-	2.0 TDCI	QXBA, QXBB	103	140	4		1.3.2007		D	
FORD	S-MAX	2.0 TDCI	QXBA, QXBB	103	140	4		1.5.2006		D	

Brand	Model	Motorization	Engine	Kw	Hp	Cylinders	Valves	From Date	To Date	Fuel	OEM
FORD	TRANSIT Bus	2.4 DI (F_B_, F_C_, F_A_)	D2FA	66	90	4	4	1.1.2000	1.5.2006	D	4C1Q68319AA
FORD	TRANSIT Bus	2.4 DI (RWD) (F_B_, F_C_)	F4FA	55	75	4	4	1.1.2000	1.5.2006	D	4C1Q68319AB
FORD	TRANSIT Bus	2.4 DI (RWD) (F_B_, F_C_, F_A_)	D4FA	88	120	4	2	1.1.2000	1.5.2006	D	1226639
FORD	TRANSIT Bus	2.4 TDCI	H9FA	101	137	4	4	1.3.2004	1.5.2006	D	1329202
FORD	TRANSIT Bus	2.4 TDE (F_C_, F_B_, F_A_)	DOFA	92	125	4	4	1.7.2001	1.5.2006	D	



Stock No: 3013

Stock No: 3031

Brand	Model	Motorization	Engine	Kw	Hp	Cylinders	Valves	From Date	To Date	Fuel	OEM
FORD	FOCUS C-MAX	1.6 TI	HWDA, HWDB	74	100	4		01.10.2003	01.03.2007	D	1305986
FORD	C-MAX	1.6	HWDA, HWDB	74	100	4		01.02.2007		D	1490906
FORD	FOCUS II (DA_)	1.4 - 1.6 i/g	ASDA, ASDB	59	80	4		01.11.2004		D	4MSG683212A
FORD	FOCUS II Stufenheck (DA_)	1.4	ASDA, ASDB	59	80	4		01.04.2005		D	4MSG683212B
FORD	FOCUS II Kombi (DAW_)	1.6 i/g	SIDA	85	115	4		01.11.2004		D	
FORD	FOCUS II Cabriolet	1.6	HWDA, HWDB	74	100	4		01.10.2006		D	
FORD	FOCUS III	1.6 Ecoboost	PNDA	134	182	4		01.04.2011		D	
FORD	FOCUS III Stufenheck	1.6	PNDA	92	125	4		01.04.2011		D	
FORD	FOCUS III Turnier	1.6 TI	PNDA	92	125	4		01.05.2011		D	
FORD	MONDEO IV	1.6 TI	RHBA	81	110	4		01.03.2007		D	
FORD	MONDEO IV Stufenheck	1.6 TI	RHBA	81	110	4		01.03.2007		D	
FORD	MONDEO IV Turnier	1.6 TI	RHBA	81	110	4		01.03.2007		D	

Brand	Model	Motorization	Engine	Kw	Hp	Cylinders	Valves	From Date	To Date	Fuel	OEM
FORD	TRANSIT Box	2.2 TDCI	QWFA	96	130	4	4	01.07.2006	-	D	1387095
FORD	TRANSIT Bus	2.2 TDCI	QWFA	96	130	4	4	01.07.2006	-	D	8K2Q68319BA
FORD	TRANSIT Flatbed / Chassis	2.2 TDCI	QWFA	96	130	4	4	01.07.2006	-	D	8C1Q68319CC



Stock No: 3032

Brand	Model	Motorization	Engine	Kw	Hp	Cylinders	Valves	From Date	To Date	Fuel	OEM
FORD	RANGER	2.5 TDCI								D	3M346A312FC

1418699



FORD

Stock No: 5081

Brand	Model	Motorization	Engine	Kw	Hp	Cylinders	Valves	From Date	To Date	Fuel	OEM
FORD	FIESTA MK III	1.8 XR3i 16V		96	130	4		01.02.1992	01.12.1995	P	928M6B3200E
FORD	FIESTA MK III	1.6 i 16V		65	88	4		01.01.1994	02.12.1995	P	
FORD	ESCORT MK V	1.8 15V XR3i		77	105	4		01.02.1992	01.12.1992	P	
FORD	ESCORT MK V	1.8 15V XR3i		96	130	4		01.02.1992	01.12.1992	P	
FORD	ORION MK III	1.6 i 16V		65	90	4		01.07.1992	01.12.1993	P	
FORD	ORION MK III	1.8 i 16V		77	105	4		01.02.1992	01.12.1993	P	
FORD	ORION MK III	1.8 i 16V		96	130	4		01.01.1992	01.12.1993	P	
FORD	MONDEO (GBP)	1.6 i 16V		65	90	4		01.02.1993	01.08.1996	P	
FORD	MONDEO (GBP)	1.8 i 16V		85	115	4		01.02.1993	01.08.1996	P	
FORD	MONDEO (GBP)	2.0 i 16V		100	136	4		01.02.1993	01.08.1996	P	
FORD	MONDEO (GBP)	1.8 i 16V		82	112	4		01.07.1994	01.08.1996	P	
FORD	MONDEO (GBP)	1.6 i 16V		65	88	4		01.07.1994	01.08.1996	P	
FORD	MONDEO (GBP)	2.0 i 16V 4x4		97	132	4		01.12.1994	01.08.1996	P	
FORD	MONDEO (GBP)	2.0 i 16V		97	132	4		01.12.1994	01.08.1996	P	
FORD	MONDEO (GBP)	1.8 i 16V 4x4		85	115	4		01.02.1993	01.08.1996	P	
FORD	MONDEO Saloon (GBP)	1.6 i 16V		65	90	4		01.02.1993	01.08.1996	P	
FORD	MONDEO Saloon (GBP)	1.8 i 16V		85	115	4		01.02.1993	01.08.1996	P	
FORD	MONDEO Saloon (GBP)	2.0 i 16V		100	136	4		01.02.1993	01.08.1996	P	
FORD	MONDEO Saloon (GBP)	1.8 i 16V		82	112	4		01.01.1994	01.08.1996	P	
FORD	MONDEO Saloon (GBP)	1.6 i 16V		65	88	4		01.07.1994	01.08.1996	P	
FORD	MONDEO Saloon (GBP)	2.0 i 16V 4x4		97	132	4		01.12.1994	01.08.1996	P	
FORD	MONDEO Saloon (GBP)	1.8 4x4		85	116	4		01.02.1993	01.08.1994	P	
FORD	ESCORT Mk Vi (GAL)	1.8 TD		66	90	4		01.02.1993	01.01.1995	D	
FORD	ESCORT Mk Vi (GAL)	1.6 i 16V		65	90	4		01.09.1992	01.01.1995	P	
FORD	ESCORT Mk Vi (GAL)	1.8 i 16V		77	105	4		01.09.1992	01.01.1995	P	
FORD	ESCORT Mk Vi (GAL)	1.8 XR3i 16V 4x4		77	105	4		01.08.1993	01.01.1995	P	
FORD	ESCORT Mk Vi (GAL)	1.6 i 16V		65	88	4		01.01.1994	01.01.1995	P	
FORD	ESCORT Mk Vi (GAL)	1.8 i 16V		77	105	4		01.09.1992	01.01.1995	P	
FORD	ESCORT Mk Vi (GAL)	1.8 15V XR3i		96	130	4		01.09.1992	01.01.1995	P	
FORD	ESCORT Mk V Estate (GAL, AVL)	1.8 16V		77	105	4		01.02.1992	01.12.1992	P	
FORD	ESCORT Mk V Convertible (ALL)	1.8 15V XR3i		77	105	4		01.02.1992	01.12.1992	P	
FORD	ESCORT Mk V Convertible (ALL)	1.8 15V XR3i		96	130	4		01.02.1992	01.12.1992	P	
FORD	MONDEO Estate (BNP)	1.6 i 16V		66	90	4		01.04.1993	01.08.1996	P	
FORD	MONDEO Estate (BNP)	1.8 i 16V		85	115	4		01.04.1993	01.08.1996	P	
FORD	MONDEO Estate (BNP)	2.0 i 16V		100	136	4		01.04.1993	01.08.1996	P	
FORD	MONDEO Estate (BNP)	1.6 i 16V		82	112	4		01.07.1994	01.08.1996	P	
FORD	MONDEO Estate (BNP)	1.6 i 16V		65	88	4		01.07.1994	01.08.1996	P	
FORD	MONDEO Estate (BNP)	2.0 i 16V 4x4		97	132	4		01.12.1994	01.08.1996	P	
FORD	MONDEO Estate (BNP)	2.0 i 16V		97	132	4		01.01.1993	01.08.1996	P	
FORD	MONDEO Estate (BNP)	1.8 i 16V 4x4		85	115	4		01.04.1993	01.08.1996	P	
FORD	MONDEO Estate (BNP)	2.0 i 16V 4x4		100	136	4		01.04.1993	01.08.1996	P	
FORD	ESCORT Mk Vi Convertible (ALL)	1.6 15V XR3i		66	90	4		01.12.1992	01.01.1995	P	
FORD	ESCORT Mk Vi Convertible (ALL)	1.6 i 16V		65	88	4		01.02.1994	01.01.1995	P	
FORD	ESCORT Mk Vi Convertible (ALL)	1.8 15V XR3i		96	130	4		01.12.1992	01.01.1995	P	

Brand	Model	Motorization	Engine	Kw	Hp	Cylinders	Valves	From Date	To Date	Fuel	OEM
FORD	ESCORT Mk Vi Convertible (ALL)	1.8 16V XR3i		77	105	4		01.12.1992	01.01.1995	P	
FORD	ESCORT Mk Vi Estate (GAL)	1.8 TD		66	90	4		01.02.1993	01.01.1995	D	
FORD	ESCORT Mk Vi Estate (GAL)	1.6 i 16V		66	90	4		01.09.1992	01.01.1995	P	
FORD	ESCORT Mk Vi Estate (GAL)	1.8 i 16V		96	130	4		01.02.1993	01.01.1995	P	
FORD	ESCORT Mk Vi Estate (GAL)	1.6 i 16V		65	88	4		01.01.1994	01.01.1995	P	
FORD	ESCORT Mk Vi Estate (GAL)	1.8 i 16V		77	105	4		01.01.1993	01.01.1995	P	
FORD	ESCORT Mk Vi Saloon (GAL)	1.6 i 16V		65	88	4		01.01.1994	01.01.1995	P	
FORD	ESCORT Mk Vi Saloon (GAL)	1.6 i 16V		66	90	4		01.08.1993	01.01.1995	P	
FORD	ESCORT Mk Vi Saloon (GAL)	1.8 i 16V		77	105	4		01.08.1993	01.01.1995	P	
FORD	ESCORT Mk Vi Saloon (GAL)	1.8 TD		66	90	4		01.08.1993	01.01.1995	P	
FORD	ESCORT Mk VII (GAL, AAL, ABL)	1.6 16V 4x4		66	90	4		01.01.1995	01.10.1998	P	
FORD	ESCORT Mk VII (GAL, AAL, ABL)	1.8 16V		85	115	4		01.01.1995	01.10.1998	P	
FORD	ESCORT Mk VII (GAL, AAL, ABL)	1.8 Turbo D		51	70	4		01.12.1995	01.10.1998	P	
FORD	ESCORT Mk VII (GAL, AAL, ABL)	1.6 16V		66	90	4		01.01.1995	01.10.1998	P	
FORD	ESCORT Mk VII (GAL, AAL, ABL)	1.8 TD		66	90	4		01.01.1995	01.10.1998	P	
FORD	ESCORT Mk VII Saloon (GAL, AFL)	1.6 16V		85	115	4		01.01.1995	01.02.1999	P	
FORD	ESCORT Mk VII Saloon (GAL, AFL)	1.8 Turbo D		51	70	4		01.12.1995	01.02.1999	D	
FORD	ESCORT Mk VII Saloon (GAL, AFL)	1.6 i 16V		66	90	4		01.01.1995	01.02.1999	P	
FORD	ESCORT Mk VII Saloon (GAL, AFL)	1.8 TD		66	90	4		01.01.1995	01.10.1998	D	
FORD	ESCORT Mk VII Saloon (GAL, AFL)	1.8 16V		77	105	4		01.01.1995	01.08.1995	P	
FORD	ESCORT Mk VII Saloon (GAL, AFL)	1.6 i 16V		65	88	4		01.01.1995	01.08.1995	P	
FORD	ESCORT Mk VII Estate (GAL, ANL)	1.8 16V		85	115	4		01.01.1995	01.02.1999	P	
FORD	ESCORT Mk VII Estate (GAL, ANL)	1.8 Turbo D		51	70	4		01.12.1995	01.02.1999	D	
FORD	ESCORT Mk VII Estate (GAL, ANL)	1.6 16V		66	90	4		01.01.1995	01.02.1999	P	
FORD	ESCORT Mk VII Estate (GAL, ANL)	1.8 TD		66	90	4		01.01.1995	01.02.1999	D	
FORD	ESCORT Mk VII Estate (GAL, ANL)	1.8 16V		77	105	4		01.01.1995	01.02.1999	P	
FORD	ESCORT Mk VII Estate (GAL, ANL)	1.6 i 16V		65	88	4		01.01.1995	01.02.1999	P	
FORD	ESCORT Mk VII Convertible (ALL)	1.6 16V XR3i		65	88	4		01.02.1995	01.12.1995	P	
FORD	ESCORT Mk VII Convertible (ALL)	1.6 16V XR3i		66	90	4		01.02.1995	01.09.1999	P	
FORD	ESCORT Mk VII Convertible (ALL)	1.8 TD		66	90	4		01.06.1995	01.08.1998	D	
FORD	ESCORT Mk VII Convertible (ALL)	1.8 16V XR3i		85	115	4		01.10.1995	01.08.1998	P	
FORD	ESCORT Mk VII Convertible (ALL)	1.8 Turbo D		51	70	4		01.10.1996	01.08.1999	D	
FORD	ESCORT Mk VII Convertible (ALL)	1.8 16V XR3i		96	130	4		01.02.1995	01.08.2000	P	
FORD	ESCORT Mk VII Convertible (ALL)	1.8 16V XR3i		77	105	4		01.02.1995	01.08.1998	P	
FORD	COUGAR (EC)	2.0 16V		96	131	4		01.06.1998	01.12.2001	P	
FORD	FOCUS (DAW, DBN)	1.6 16V		74	100	4		01.10.1998	01.11.2004	P	
FORD	FOCUS (DAW, DBN)	1.8 16V		85	115	4		01.10.1998	01.11.2004	P	
FORD	FOCUS Saloon (DFW)	1.6 16V		74	100	4		01.02.1999	01.11.2004	P	
FORD	FOCUS Saloon (DFW)	1.8 16V		85	115	4		01.02.1999	01.11.2004	P	
FORD	FOCUS Clipper (DMW)	1.6 16V		74	100	4		01.02.1999	01.11.2004	P	
FORD	FOCUS Clipper (DMW)	1.8 16V		85	115	4		01.02.1999	01.11.2004	P	
FORD	MONDEO Mk II (BAP)	1.6 i 16V		70	95	4		01.05.1998	01.11.2000	P	
FORD	MONDEO Mk II Saloon (BPP)	1.6 i 16V		70	95	4		01.05.1998	01.11.2000	P	
FORD	MONDEO Mk II Estate (BNP)	1.6 i 16V		70	95	4		01.05.1998	01.11.2000	P	
FORD	ESCORT '95 Box (AVL)	1.8 Turbo D		51	70	4		01.12.1995	01.06.2001	D	
FORD	ESCAPE	2.0 16V		91	124	4		01.02.2001	-	P	
FORD	ESCORT CLASSIC (AAL, ABL)	1.8 TD		66	90	4		01.10.1998	01.07.2000	D	
FORD	ESCORT CLASSIC (AAL, ABL)	1.6 16V		66	90	4		01.10.1998	01.07.2000	P	
FORD	ESCORT CLASSIC Turner (ANL)	1.6 16V		66	90	4		01.02.1999	01.07.2000	P	
FORD	ESCORT CLASSIC Turner (ANL)	1.8 TD		66	90	4		01.02.1999	01.07.2000	D	
FORD	TOURNEO CONNECT	1.8 16V		85	116	4		01.06.2002	-	P	



MERCEDES - BENZ

MERCEDES - BENZ

Stock No: 5016

Stock No: 5017

Brand	Model	Motorization	Engine	Kw	Hp	Cylinders	Valves	From Date	To Date	Fuel	OEM
MERCEDES BENZ	C-CLASS (W203)	C200 CDI	OM 646.962	75	102	4		01.05.2000	-	D	6110300303
MERCEDES BENZ	C-CLASS T-Model (S203)	C200 - C270 CDI	OM 646.963	110	150	4		01.03.2001	-	D	6110301703
MERCEDES BENZ	C-CLASS Coupe (CL203)	C200 CDI	OM 646.963	90	122	4		01.03.2001	-	D	61 0003
MERCEDES BENZ	CLC-CLASS	CLC200 CDI	OM 646.962	110	150	4		01.05.2008	-	D	
MERCEDES BENZ	CLK (C209)	270 CDI	OM 612.962, OM 612.967*	125	170	5		01.05.2002	-	D	
MERCEDES BENZ	E-CLASS (W210)	E200-E270 CDI	OM 612.961	105	143	5		01.06.1996	01.03.2003	D	
MERCEDES BENZ	E-CLASS Kombi (S210)	E220-E270 T CDI	OM 612.961	105	143	4		01.06.1996	01.03.2003	D	
MERCEDES BENZ	E-CLASS (W211)	E200-E270 CDI	OM 646.951	90	122	4		01.03.2002	-	D	
MERCEDES BENZ	E-CLASS T-Model (S211)	E220-E270 T CDI	OM 646.961	110	150	4		01.03.2003	-	D	
MERCEDES BENZ	SPRINTER 2-t Bus (901, 902)	216 CDI	OM 612.961	115	156	5		01.01.1995	01.05.2006	D	
MERCEDES BENZ	SPRINTER 2-t K (901, 902)	216 CDI	OM 612.961	115	156	5		01.01.1995	01.05.2006	D	
MERCEDES BENZ	"SPRINTER 2-t F/ Fahrgestell"	216 CDI	OM 612.961	115	156	5		01.01.1995	01.05.2006	D	
MERCEDES BENZ	SPRINTER 3-t Bus (903)	316 CDI	OM 612.961	115	156	5		01.01.1995	01.05.2006	D	
MERCEDES BENZ	SPRINTER 3-t Kasten (903)	316 CDI	OM 612.961	115	156	5		01.01.1995	01.05.2006	D	
MERCEDES BENZ	"SPRINTER 3-t F/ Fahrgestell"	316 CDI	OM 612.961	115	156	5		01.01.1995	01.05.2006	D	
MERCEDES BENZ	SPRINTER 4-t Kasten (904)	416 CDI	OM 612.961	115	156	5		01.02.1996	01.05.2006	D	
MERCEDES BENZ	"SPRINTER 4-t F/ Fahrgestell"	416 CDI	OM 612.961	115	156	5		01.02.1996	01.05.2006	D	

Brand	Model	Motorization	Engine	Kw	Hp	Cylinders	From Date	To Date	Fuel	OEM
MERCEDES BENZ	C-CLASS (W202)	C200 CDI	OM 611.960	75	102	4	01.03.1993	01.05.2000	D	6110300103
MERCEDES BENZ	C-CLASS Kombi (S202)	C200 T CDI	OM 611.960	75	102	4	01.06.1996	01.03.2001	D	6110300203
MERCEDES BENZ	C-CLASS (W203)	C220 CDI	OM 611.962	110	150	4	01.05.2000	-	D	6460300503
MERCEDES BENZ	C-CLASS T-Model (S203)	C220 CDI	OM 611.962	105	143	4	01.03.2001	-	D	6450300903
MERCEDES BENZ	C-CLASS Coupe (CL203)	C220 CDI	OM 611.962	110	150	4	01.03.2001	-	D	
MERCEDES BENZ	C CLASS (W204)	C220 CDI	OM 646.611	125	170	4	01.01.2007	-	D	
MERCEDES BENZ	C CLASS T-Model (S204)	C220 CDI	OM 646.611	125	170	4	01.06.2007	-	D	
MERCEDES BENZ	CLK (C209)	220 CDI	OM 646.966	110	150	4	01.05.2002	-	D	
MERCEDES BENZ	E-CLASS (W210)	E200-E220 CDI	OM 611.961	105	143	4	01.06.1996	01.03.2002	D	
MERCEDES BENZ	E-CLASS Kombi (S210)	E220 T CDI	OM 611.961	92	125	4	01.06.1996	01.03.2003	D	
MERCEDES BENZ	E-CLASS (W211)	E200-E220 CDI	OM 646.951	75	102	4	01.03.2002	-	D	
MERCEDES BENZ	E-CLASS T-Model (S211)	E200 CDI E220 T CDI	OM 646.961	100	136	4	01.03.2003	-	D	
MERCEDES BENZ	V-CLASS (638/2)	V200-220 CDI	OM 611.960	90	122	4	01.02.1996	01.07.2003	D	
MERCEDES BENZ	VITO Bus (638)	106 - 110 - 112 CDI 2.2	OM 611A	60	82	4	01.02.1996	01.07.2003	D	
MERCEDES BENZ	VITO Kasten (638)	106 - 112 CDI 2.2	OM 611LA	75	102	4	01.03.1996	01.07.2003	D	
MERCEDES BENZ	SPRINTER 2-t Bus (901, 902)	208 - 211 - 213 CDI 2.2	OM 611.967	80	109	4	01.01.1995	01.05.2006	D	
MERCEDES BENZ	SPRINTER 2-t Kasten (901, 902)	208 - 211 - 213 CDI	OM 611.967	95	129	4	01.01.1995	01.05.2006	D	
MERCEDES BENZ	SPRINTER 2-t P/F (901, 902)	208 - 211 - 213 CDI	OM 611.967	95	129	4	01.01.1995	01.05.2006	D	
MERCEDES BENZ	SPRINTER 3-t Bus (903)	308 - 311 - 313 CDI	OM 611.967	80	109	4	01.01.1995	01.05.2006	D	
MERCEDES BENZ	SPRINTER 3-t Kasten (903)	308 - 311 - 313 CDI	OM 611.967	80	109	4	01.01.1995	01.05.2006	D	
MERCEDES BENZ	SPRINTER 3-t P/F (903)	308 - 311 - 313 CDI	OM 611.967	80	109	4	01.01.1995	01.05.2006	D	
MERCEDES BENZ	SPRINTER 4-t Kasten (904)	408 - 411 - 413 CDI	OM 611.967	95	129	4	01.02.1996	01.05.2006	D	
MERCEDES BENZ	SPRINTER 4-t P/F (904)	408 - 411 - 413 CDI	OM 611.967	95	129	4	01.02.1996	01.05.2006	D	



OPEL - SAAB
SUZUKI

Stock No: 5080

Brand	Model	Motorization	Engine	Kw	Hp	Cylinders	From Date	To Date	Fuel	OEM
OPEL	VECTRA B (36)	2.0 DI 16V	60	82	4	01.11.1996	01.04.2002	D		514411
OPEL	VECTRA B (36)	2.0 DTI 16V	74	101	4	01.06.1997	01.04.2002	D		55351711
OPEL	VECTRA B (36)	2.2 DTI 16V	92	125	4	01.09.2000	01.04.2002	D		5614437
OPEL	VECTRA B Hatchback (36)	2.0 DI 16V	60	82	4	01.11.1996	01.06.2000	D		9126177
OPEL	VECTRA B Hatchback (36)	2.0 DTI 16V	74	101	4	01.06.1997	01.07.2003	D		
OPEL	VECTRA B Hatchback (36)	2.2 DTI 16V	92	125	4	01.09.2000	01.07.2003	D		
OPEL	VECTRA B Estate (31)	2.0 DI 16V	60	82	4	01.11.1996	01.06.2000	D		
OPEL	VECTRA B Estate (31)	2.0 DTI 16V	74	101	4	01.06.1997	01.07.2003	D		
OPEL	VECTRA B Estate (31)	2.2 DTI 16V	92	125	4	01.09.2000	01.07.2003	D		
OPEL	SINTRA	2.2 DTI	85	116	4	01.07.1997	01.04.1999	D		
OPEL	ASTRA G Hatchback (F48, F08)	2.0 DI	60	82	4	01.02.1996	01.01.2005	D		
OPEL	ASTRA G Hatchback (F48, F08)	2.0 DTI 16V	74	101	4	01.08.1999	01.01.2005	D		
OPEL	ASTRA G Hatchback (F48, F08)	2.2 DTI	92	125	4	01.09.2002	01.01.2005	D		
OPEL	ASTRA G Estate (F35)	2.0 DI	60	82	4	01.02.1996	01.07.2004	D		
OPEL	ASTRA G Estate (F35)	2.0 DTI 16V	74	101	4	01.06.1999	01.07.2004	D		
OPEL	ASTRA G Estate (F35)	2.2 DTI	92	125	4	01.09.2002	01.07.2004	D		
OPEL	OMEGA B (25, 26, 27)	2.0 DTI 16V	74	101	4	01.09.1997	01.09.2000	D		
OPEL	OMEGA B (25, 26, 27)	2.2 DTI 16V	88	120	4	01.09.2000	01.07.2003	D		
OPEL	OMEGA B Estate (21, 22, 23)	2.0 DTI 16V	74	101	4	01.09.1997	01.09.2000	D		
OPEL	OMEGA B Estate (21, 22, 23)	2.2 DTI 16V	88	120	4	01.09.2000	01.07.2003	D		
OPEL	FRONTERA B (66)	2.2 DTI	85	116	4	01.10.1996	01.09.2002	D		
OPEL	FRONTERA B (66)	2.2 DTI	88	120	4	01.09.2002		D		
OPEL	SEVATOR B (29)	2.5 I	103	140	6	01.09.1990	01.09.1993	F		
OPEL	ZAFIRA (F75)	2.0 DI 16V	60	82	4	01.10.1999	01.06.2005	D		
OPEL	ZAFIRA (F75)	2.0 DTI 16V	74	101	4	01.09.2000	01.06.2005	D		
OPEL	ZAFIRA (F75)	2.2 DTI 16V	92	125	4	01.01.2002	01.06.2005	D		
OPEL	ASTRA G Saloon (F69)	2.0 DTI 16V	74	101	4	01.08.1999	01.01.2005	D		
OPEL	ASTRA G Saloon (F69)	2.2 DTI	92	125	4	01.09.2002	01.01.2005	D		
OPEL	ASTRA G Delivan (F70)	2.0 DI	60	82	4	01.01.1999	01.04.2005	D		
OPEL	VECTRA C	2.2 DTI 16V	92	125	4	01.04.2002		D		
OPEL	VECTRA C	2.0 DTI 16V	74	101	4	01.04.2002		D		
OPEL	VECTRA C GTS	2.0 DTI 16V	74	101	4	01.08.2002		D		
OPEL	VECTRA C GTS	2.2 DTI 16V	92	125	4	01.08.2002	01.08.2002	D		
OPEL	ASTRA G Convertible	2.2 DTI	92	125	4	01.09.2002	01.10.2005	D		
OPEL	ASTRA G Coupe (F07)	2.2 DTI	92	125	4	01.09.2002	01.09.2005	D		
OPEL	SIGNUM	2.0 DTI	74	100	4	01.05.2003		D		
OPEL	SIGNUM	2.2 DTI	92	125	4	01.05.2003		D		
OPEL	VECTRA C Estate	2.2 DTI	92	125	4	01.10.2003		D		
OPEL	VECTRA C Estate	2.0 DTI	74	100	4	01.10.2003		D		
OPEL	ASTRA F CLASSIC Hatchback	2.0 DI	60	82	4	01.03.1996	01.08.2000	D		
OPEL	ASTRA F CLASSIC Hatchback	2.0 DTI	74	101	4	01.08.1999	01.08.2000	D		
VAUXHALL	VECTRA (B)	2.0 DI 16V	60	82	4	01.08.1995	01.10.2001	D		
VAUXHALL	VECTRA (B)	2.0 DTI 16V	74	101	4	01.08.1995	01.10.2001	D		
VAUXHALL	VECTRA (B)	2.2 DTI 16V	92	125	4	01.08.1995	01.10.2001	D		
VAUXHALL	VECTRA (B) Hatchback	2.0 DI 16V	60	82	4	01.08.1995	01.10.2001	D		
VAUXHALL	VECTRA (B) Hatchback	2.0 DTI 16V	74	101	4	01.06.1997	01.10.2001	D		
VAUXHALL	VECTRA (B) Hatchback	2.2 DTI 16V	92	125	4	01.08.1995	01.10.2001	D		
VAUXHALL	VECTRA (B) Estate	2.0 DI 16V	60	82	4	01.08.1995	01.10.2001	D		
VAUXHALL	VECTRA (B) Estate	2.0 DTI 16V	74	101	4	01.08.1995	01.10.2001	D		
VAUXHALL	VECTRA (B) Estate	2.2 DTI 16V	92	125	4	01.08.1995	01.10.2001	D		
VAUXHALL	FRONTERA Mk II (B)	2.2 DTI	85	116	4	01.10.1996	01.09.2004	D		

MERCEDES - BENZ

Brand	Model	Motorization	Engine	Kw	Hp	Cylinders	From Date	To Date	Fuel	OEM
VAUXHALL	ASTRA IV (G) HATCHBACK	2.0 DI		60	82	4	1.2.1996		D	
VAUXHALL	ASTRA IV (G) HATCHBACK	2.0 DTI 16V		74	101	4	1.8.1999		D	
VAUXHALL	ASTRA MK IV (G)	2.0 DI		60	82	4	1.2.1996	1.7.2004	D	
VAUXHALL	ASTRA MK IV (G)	2.0 DTI 16V		74	101	4	1.2.1996	1.7.2004	D	
VAUXHALL	ASTRA MK IV (G) ESTATE	2.0 DI		60	82	4	1.3.1996	1.4.2004	D	
VAUXHALL	ASTRA MK IV (G) ESTATE	2.0 DTI 16V		74	101	4	1.3.1996	1.4.2004	D	
VAUXHALL	SINTRA	2.0 DTI		85	116	4	1.7.1997	1.4.1999	D	
VAUXHALL	ZAFIRA MK I (A) (F75)	2.0 DI 16V		60	82	4	1.10.1999		D	
VAUXHALL	ZAFIRA MK I (A) (F75)	2.0 DTI 16V		74	101	4	1.4.1999		D	
VAUXHALL	ASTRA MK IV (G)	2.0 DI		60	82	4	1.8.1996		D	
VAUXHALL	ASTRA MK IV (G)	2.0 DTI		74	100	4	1.4.1999		D	
VAUXHALL	VECTRA MK II @	2.0 DTI 16V		74	101	4	1.4.2002	1.7.2008	D	
VAUXHALL	VECTRA MK II @	2.2 DTI 16V		92	125	4	1.4.2002	1.7.2008	D	
VAUXHALL	VECTRA MK II @ GTS	2.2 DTI 16V		92	125	4	1.4.2002		D	
VAUXHALL	VECTRA MK II @ GTS	2.0 DTI 16V		74	101	4	1.8.2002		D	
VAUXHALL	SIGNUM	2.0 DTI		74	100	4	1.8.2002	1.7.2008	D	
VAUXHALL	SIGNUM	2.2 DTI		92	125	4	1.5.2003	1.7.2008	D	
VAUXHALL	VECTRA MK II @ ESTATE	2.0 DTI 16V		74	101	4	1.5.2003	1.11.2000	D	
VAUXHALL	VECTRA MK II @ ESTATE	2.2 DTI 16V		92	125	4	1.10.2003	1.9.2002	D	
SAAB	9-3 (Y33D)	2.2 TID		85	115	4	1.10.2003		D	
SAAB	9-3 (Y33D)	2.2 TID		92	125	4	1.2.1996		D	
SAAB	9-5 SALOON (Y33E)	2.2 TID		88	120	4	1.11.2000		D	
SAAB	9-5 ESTATE (Y33E)	2.2 TID		88	120	4	1.3.2002		D	
SAAB	9-3 SALOON (Y33E)	2.2 TID		92	125	4	1.3.2002		D	



Stock No: 5001

Brand	Model	Motorization	Engine	Kw	Hp	Cylinders	Valves	From Date	To Date	Fuel	OEM
OPEL	ASTRA H	1.9 CDTI	Z 19 DT	88	120	4	2	01.06.2004	-	D	55196301
OPEL	ASTRA H	1.9 CDTI	Z 19 DTH	110	150	4	4	01.09.2004	-	D	5614445
OPEL	SIGNUM	1.9 CDTI	Z 19 DT	88	120	4	2	01.04.2004	-	D	614352
OPEL	SIGNUM	1.9 CDTI	Z 19 DTH	110	150	4	4	01.04.2004	-	D	1251079J50
OPEL	VECTRA C	1.9 CDTI	Z 19 DT	88	120	4	2	01.04.2004	-	D	
OPEL	VECTRA C	1.9 CDTI	Z 19 DTH	110	150	4	4	01.04.2004	-	D	
OPEL	ZAFIRA	1.9 CDTI	Z 19 DT	88	120	4	2	01.07.2006	-	D	
OPEL	ZAFIRA	1.9 CDTI	Z 19 DTH	110	150	4	4	01.07.2006	-	D	
SAAB	9-3 (Y33F)	1.9 TID	Z19DT	88	120	4	2	01.09.2004	-	D	
SAAB	9-3 (Y33F)	1.9 TID	Z19DTH	110	150	4	4	01.09.2004	-	D	
SAAB	9-5 (Y33E)	1.9 TID	Z19DTH	110	150	4	4	01.01.2006	-	D	
SUZUKI	SK4 (G4)	1.9 DOIS	D19AA	88	120	4	2	01.06.2006	-	D	



OPEL - SAAB
SUZUKI

Stock No: 5008

Brand	Model	Motorization	Engine	Kw	Hip	Cylinders	Valves	From Date	To Date	Fuel	OEM
OPEL	AGILA (H00)	1.3 CDTI	2 13 DT	51	70	4	4	01.08.2003	-	D	5614438
OPEL	ASTRA H	1.3 CDTI	2 13 DTH	66	90	4	4	01.08.2005	-	D	614150
OPEL	ASTRA H Estate	1.3 CDTI	2 13 DTH	66	90	4	4	01.08.2005	-	D	93194443
OPEL	COMBO Box Body / Estate	1.3 CDTI 16V	2 13 DT	51	69	4	4	01.08.2005	-	D	931177317
OPEL	COMBO Box Body / Estate	1.3 CDTI 16V	2 13 DTJ	55	75	4	4	01.10.2005	-	D	
OPEL	CORSA C (F08, F66)	1.3 CDTI	2 13 DT	51	70	4	4	01.06.2003	-	D	
OPEL	CORSA D	1.3 CDTI	2 13 DTH	66	90	4	4	01.07.2006	-	D	
OPEL	CORSA D	1.3 CDTI	2 13 DTJ	55	75	4	4	01.07.2006	-	D	
OPEL	MERIVA	1.3 CDTI	2 13 DTJ	55	75	4	4	01.09.2003	-	D	
OPEL	TIGRA TwinTop	1.3 CDTI	2 13 DT	51	69	4	4	01.06.2004	-	D	



Stock No: 5026

Brand	Model	Motorization	Engine	Kw	Hip	Cylinders	Valves	From Date	To Date	Fuel	OEM
OPEL	MOVANO Combi (J9)	1.9 DTI	F9Q 774	60	82	4	4	01.07.1998	-	D	4413748 - 4413749
OPEL	MOVANO Kasten (F9)	1.9 DTI	F9Q 774	60	82	4	4	01.01.1999	-	D	4414115
OPEL	VIVARO Combi (J7)	1.9 DTI	F9Q 760	74	101	4	4	01.08.2001	-	D	4414116
OPEL	VIVARO Kasten (F7)	1.9 DTI	F9Q 762	74	101	4	4	01.08.2001	-	D	93161258
OPEL	VIVARO Pritsche/Fahrgestell (E7)	1.9 DTI	F9Q 760	74	101	4	4	01.01.2006	-	D	93161259
VAUXHALL	MOVANO Van (FD)	1.9 DTI	F9Q 774	60	82	4	4	01.10.1998	-	D	931170224
VAUXHALL	VIVARO Kasten	1.9 DTI	F9Q 760	74	101	4	4	01.10.1998	-	D	931170225



Stock No: 5028

Brand	Model	Motorization	Engine	Kw	Hip	Cylinders	Valves	From Date	To Date	Fuel	OEM
OPEL	VIVARO Combi (J7)	2.5 DTI	G9U 730	99	135	4	4	01.08.2001	-	D	93196099
OPEL	VIVARO Kasten (F7)	2.5 DTI	G9U 730	99	135	4	4	01.08.2001	-	D	93196115
VAUXHALL	VIVARO Kasten	2.5 DTI	G9U 730	99	135	4	4	01.08.2001	-	D	4418795

4433554



CITROEN - PEUGEOT

Stock No: 5003

Brand	Model	Motorization	Engine	Kw	Hip	Cylinders	Valves	From Date	To Date	Fuel	OEM
CITROEN	BERLINGO (MF)	1.9 D (MPWJZ)	WJY (DW8B)	51	70	4	2	01.07.1998	-	D	0515F2
CITROEN	BERLINGO (MF)	2.0 HDI 90 (MFRHY)	RHY (DW10TD)	66	90	4	2	01.12.1999	-	D	0515T8
CITROEN	C5 (DC_)	2.0 HDI (DCRHYE)	RHY (DW10TD)	66	90	4	2	01.03.2001	01.08.2004	D	0515V6
CITROEN	C5 (DC_)	2.0 HDI (DCRHYE)	RHZ (DW10ATED)	80	109	4	2	01.03.2001	01.08.2004	D	0515L9
CITROEN	C5 (DC_)	2.2 HDI (DCRHYE)	4HK (DW12TE04FAP)	98	133	4	4	01.03.2001	01.08.2004	D	
CITROEN	C8 (EA_) (EB_)	2.0 HDI	RHW (DW10ATED4)	79	107	4	4	01.07.2002	-	D	
CITROEN	C8 (EA_) (EB_)	2.2 HDI	4HW (DW12TE04)	94	128	4	4	01.07.2002	-	D	
CITROEN	JUMPER Box (244)	2.0 HDI	DW10UTD	62	84	4	2	01.04.2002	-	D	
CITROEN	JUMPER Box (244)	2.2 HDI	DW12TED	74	101	4	4	01.04.2002	-	D	
CITROEN	JUMPER Flatbed / Chassis (244)	2.0 HDI	DW10UTD	62	84	4	2	01.04.2002	-	D	
CITROEN	JUMPER Flatbed / Chassis (244)	2.2 HDI 19V	DW12TED	74	101	4	4	01.04.2002	-	D	
CITROEN	JUMPY Box (B2_) (BY_) (BZ_)	2.0 HDI 95	RHX (DW10BTE0)	69	94	4	2	01.10.1999	-	D	
CITROEN	XANTIA (X2)	2.0 HDI 109	RHZ (DW10ATED)	80	109	4	2	01.02.1999	01.04.2003	D	
CITROEN	XANTIA (X2)	2.0 HDI 90	RHY (DW10TD)	66	90	4	2	01.03.1999	01.04.2003	D	
CITROEN	XSARA (N1)	2.0 HDI 109	RHZ (DW10ATED)	80	109	4	2	01.05.2001	01.03.2006	D	
CITROEN	XSARA (N1)	2.0 HDI 90	RHY (DW10TD)	66	90	4	2	01.02.1999	01.03.2006	D	
CITROEN	XSARA Break (N2)	2.0 HDI 109	RHZ (DW10ATED)	80	109	4	2	01.05.2001	01.08.2006	D	
CITROEN	XSARA Break (N2)	2.0 HDI 90	RHY (DW10TD)	66	90	4	2	01.02.1999	01.08.2006	D	
PEUGEOT	206 Hatchback (2A/C)	1.9 D	WJY (DW8)	51	69	4	2	01.09.1998	01.11.2001	D	
PEUGEOT	206 Hatchback (2A/C)	2.0 HDI 90	RHY (DW10TD)	66	90	4	2	01.12.1999	-	D	
PEUGEOT	305 Break (7E, N3, N5)	1.9 D	WJY (DW8B)	51	69	4	2	01.09.1998	01.04.2002	D	
PEUGEOT	305 Break (7E, N3, N5)	2.0 HDI 90	RHY (DW10TD)	66	90	4	2	01.05.1999	01.04.2002	D	
PEUGEOT	305 Hatchback (7A, 7C, N3, N5)	1.9 D	WJY (DW8B)	51	69	4	2	01.09.1998	01.05.2001	D	
PEUGEOT	305 Hatchback (7A, 7C, N3, N5)	2.0 HDI 90	RHY (DW10TD)	66	90	4	2	01.05.1999	01.05.2001	D	
PEUGEOT	307 (3A/C)	2.0 HDI 110	RHS (DW10ATED)	79	107	4	2	01.08.2000	-	D	
PEUGEOT	307 (3A/C)	2.0 HDI 90	RHY (DW10TD)	66	90	4	2	01.08.2000	-	D	
PEUGEOT	406 (8B)	2.2 HDI	4HK (DW12TE04FAP)	98	133	4	4	01.03.2000	01.05.2004	D	
PEUGEOT	607 (3D, 9U)	2.0 HDI	RHZ (DW10ATED)	80	109	4	2	01.05.2000	-	D	
PEUGEOT	607 (3D, 9U)	2.2 HDI	4HK (DW12TE04FAP)	98	133	4	4	01.02.2000	-	D	
PEUGEOT	807 (E)	2.0 HDI	RHW (DW10ATED4)	79	107	4	4	01.05.2002	-	D	
PEUGEOT	807 (E)	2.2 HDI	4HK (DW12TE04FAP)	94	128	4	4	01.06.2002	-	D	
PEUGEOT	BOXER Box (244)	2.0 HDI	RHY (DW10UTD)	62	84	4	2	01.04.2002	-	D	
PEUGEOT	BOXER Box (244)	2.2 HDI	4HY (DW12UTD)	74	101	4	2	01.04.2002	-	D	
PEUGEOT	EXPERT Box (222)	1.9 D 70	WJY (DW8B)	51	69	4	2	01.12.1998	-	D	
PEUGEOT	EXPERT Box (222)	2.0 HDI	RHX (DW10BTE0)	69	94	4	2	01.07.2000	-	D	
PEUGEOT	EXPERT Box (222)	2.0 HDI	RHZ (DW10ATED)	80	109	4	2	01.07.2000	-	D	
PEUGEOT	PARTNER Box (5)	2.0 HDI	RHY (DW10TD)	66	90	4	2	01.04.2000	-	D	



CITROEN - PEUGEOT

Stock No: 5011

Brand	Model	Motorization	Engine	Kw	Hp	Cylinders	Valves	From Date	To Date	Fuel	OEM
CITROEN	BERLINGO (MF)	1.6 D (MF9A)	ASA (XUD7)	43	58	4	2	01.07.1998	-	D	0515G3
CITROEN	BERLINGO (MF)	1.9 D (MFDJ)	D9B (XUD9A/L)	50	68	4	2	01.07.1996	-	D	
CITROEN	EVASION (22, U6)	1.9 TD	D6B (XUD9TF)	66	90	4	2	01.11.1994	01.07.2002	D	
CITROEN	JUMPER Box (230L)	1.9 D	D9B (XUD9A/U)	51	69	4	2	01.02.1994	01.04.2002	D	
CITROEN	JUMPER Box (230L)	1.9 TD	DHX (XUD9TF/BTF)	66	90	4	2	01.03.1994	01.04.2002	D	
CITROEN	JUMPY (U6U)	1.9 D	D9B (XUD9A/U)	51	69	4	2	01.10.1996	01.04.1998	D	
CITROEN	JUMPY (U6U)	1.9 TD	DHX (XUD9TF/BTF)	66	90	4	2	01.10.1996	-	D	
CITROEN	XANTIA (X1)	1.9 D	DJZ (XUD9Y)	50	68	4	2	01.06.1994	01.01.1998	D	
CITROEN	XANTIA (X1)	1.9 SD	DHW (XUD9GD)	55	75	4	2	01.02.1996	01.01.1998	D	
CITROEN	XANTIA (X1)	1.9 Turbo D	DHX (XUD9TF/BTF)	66	90	4	2	01.10.1994	01.01.1998	D	
CITROEN	XANTIA Break (X1)	1.9 SD	DHW (XUD9GD)	55	75	4	2	01.04.1997	01.01.1998	D	
CITROEN	XSARA (N1)	1.9 D	DJY (XUD9A)	50	68	4	2	01.04.1997	01.09.2000	D	
CITROEN	XSARA (N1)	1.9 SD	DHY (XUD9E6SD)	55	75	4	2	01.01.1998	01.09.2000	D	
CITROEN	XSARA (N1)	1.9 TD	DHY (XUD9TE/Y)	66	90	4	2	01.04.1997	01.09.2000	D	
CITROEN	ZX (N2)	1.8 D	161A (XUD7)	44	60	4	2	01.06.1993	01.06.1997	D	
CITROEN	ZX (N2)	1.9 D	D9B (XUD9A/U)	50	68	4	2	01.06.1994	01.06.1997	D	
CITROEN	ZX (N2)	1.9 TD	DHY (XUD9TE/Y)	66	90	4	2	01.07.1992	01.06.1997	D	
PEUGEOT	505 Hatchback (7A, 7C, N6, N2)	1.8 D	ASA (XUD7)	43	58	4	2	01.05.1993	01.05.2001	D	
PEUGEOT	505 Hatchback (7A, 7C, N6, N2)	1.9 D	DJY (XUD9A)	50	68	4	2	01.06.1994	01.05.2001	D	
PEUGEOT	505 Hatchback (7A, 7C, N6, N2)	1.9 DT	DHY (XUD9TE)	66	90	4	2	01.05.1993	01.05.2001	D	
PEUGEOT	405 I (16B)	1.8 Turbo Diesel	A8A (XUD7TE)	66	90	4	2	01.03.1988	01.12.1992	D	
PEUGEOT	405 II (4B)	1.9 TD	DHY (XUD9TE)	66	90	4	2	01.08.1992	01.10.1995	D	
PEUGEOT	405 (8B)	1.9 D	DHW (XUD9GD)	55	75	4	2	01.10.1996	01.05.2004	D	
PEUGEOT	405 (8B)	1.9 TD	DHX (XUD9TE)	66	90	4	2	01.01.1996	01.05.2004	D	
PEUGEOT	806 (221)	1.9 TD	DHX (XUD9TE)	66	90	4	2	01.07.1995	01.08.2002	D	
PEUGEOT	BOXER Box (230L)	1.9 D	DJY (XUD9A)	50	68	4	2	01.07.1999	01.04.2002	D	
PEUGEOT	BOXER Box (230L)	1.9 TD	XUD9TE	66	90	4	2	01.07.1999	01.04.2002	D	
PEUGEOT	EXPERT Box (222)	1.9 D	D9B (XUD9AU)	51	70	4	2	01.02.1996	-	D	
PEUGEOT	EXPERT Box (222)	1.9 TD	DHX (XUD9TE)	66	90	4	2	01.02.1996	-	D	
PEUGEOT	PARTNER Box (5)	1.8 D	ASA (XUD7)	43	58	4	2	01.06.1996	-	D	
PEUGEOT	PARTNER Box (5)	1.9 D	DJY (XUD9A)	51	69	4	2	01.06.1996	-	D	



CITROEN - PEUGEOT

Stock No: 5005

Brand	Model	Motorization	Engine	Kw	Hp	Cylinders	Valves	From Date	To Date	Fuel	OEM
CITROEN	BERLINGO (MF)	1.9 D (MFWJZ)	WJZ (DW88)	51	70	4	2	1.7.1996	-	D	0515Q6
CITROEN	BERLINGO Box (M_)	1.9 D 70 4WD	WJZ (DW8)	51	69	4	2	1.7.1996	-	D	0515L7
CITROEN	JUMPY (U6U)	1.9 D 70	WJZ (DW8)	51	69	4	2	1.4.1996	-	D	
CITROEN	XSARA (N1)	1.9 D	WJY (DW88)	51	70	4	2	1.7.1998	1.3.2005	D	
PEUGEOT	206 Hatchback (2A/C)	1.9 D	WJZ (DW8)	51	69	4	2	1.9.1996	1.11.2001	D	
PEUGEOT	306 (7B, N3, N5)	1.9 D	WJY (DW88)	51	69	4	2	1.9.1996	1.5.2001	D	
PEUGEOT	EXPERT Box (222)	1.9 D 70	WJY (DW88)	51	69	4	2	1.12.1998	-	D	
PEUGEOT	PARTNER Box (5)	1.9 D	DJY (XUD9A)	51	69	4	2	1.6.1996	-	D	



Stock No: 5019

Brand	Model	Motorization	Engine	Kw	Hp	Cylinders	Valves	From Date	To Date	Fuel	OEM
CITROEN	AX	1.5 D	TU05	80	109	4	4	-	-	P	0515J3
CITROEN	Berlingo	1.6 16V	TU5JP	80	109	4	4	1.10.2000	-	P	
PEUGEOT	106	(Excluding New Style)		76	103	4	4	-	-	P	
PEUGEOT	405	(JUST AFTER 93)	TU5JP4S	67	118	4	4	-	-	P	
PEUGEOT	106 I	16	TU5JP4 (NFU)	76	103	4	4	1.1.1994	1.4.1996	P	
PEUGEOT	106 II	1.6i	TU5J2 (NFY) (NFW)	76	103	4	4	1.5.1996	-	P	
PEUGEOT	106 II	1.6 S16	TU5J4 (NFX)	76	103	4	4	1.5.1996	-	P	
PEUGEOT	Partner CombiSpace	1.6 16V		80	109	4	4	1.7.2001	-	P	



CITROËN - PEUGEOT

Stock No: 3027

Brand	Model	Motorization	Engine	Kw	Hip	Cylinders	Valves	From Date	To Date	Fuel	OEM
CITROËN	BERLINGO (MF)	1.6 HDi 90	DV6ATED4	66	90	4	4	1.7.2005	-	D	0515P8
CITROËN	C1 (FM_ PN_)	1.4 HDi	DV4D	40	54	4	2	1.6.2005	-	D	0515R0
CITROËN	C2 (JM_)	1.4 HDi	8HX (DV4TD)	50	68	4	2	1.9.2003	-	D	0515T0
CITROËN	C3 (FC_)	1.4 16V HDi	8HY (DV4TED4)	66	90	4	4	1.2.2002	-	D	0515TQ
CITROËN	C3 (FC_)	1.4 HDi	8HX (DV4TD)	50	68	4	2	1.2.2002	-	D	0515V0
CITROËN	C3 (FC_)	1.6 16V HDi	9HX (DV6ATED4)	66	90	4	4	1.10.2005	-	D	0515V7
CITROËN	C3 Pluriel (HB_)	1.4 HDi	8HX (DV4TD)	50	68	4	2	1.4.2004	-	D	0515V8
CITROËN	C4 (LC_)	1.6 HDi	9HX (DV6ATED4)	66	90	4	4	1.11.2004	-	D	
CITROËN	C4 (LC_)	1.6 HDi	DV6TED4	80	109	4	4	1.11.2004	-	D	
CITROËN	C5 (FC_)	1.6 HDi (RC8HZ8)	DV6TED4	80	109	4	4	1.9.2004	-	D	
CITROËN	XSARA (N1)	1.4 HDi	8HX (DV4TD)	50	68	4	2	1.1.2003	1.3.2005	D	
CITROËN	XSARA Break (N2)	1.4 HDi	8HX (DV4TD)	50	68	4	2	1.1.2003	1.8.2005	D	
CITROËN	XSARA PICASSO (N68)	1.6 HDi	DV6TED4	80	109	4	4	1.5.2004	-	D	
PEUGEOT	107 (KM_)	1.4 HDi	8HX (DV4TD)	50	68	4	2	1.4.2005	-	D	
PEUGEOT	107	1.4 HDi	GENERAL MOTOR	40	54	4	2	1.6.2005	-	D	
PEUGEOT	206 Hatchback (2A/C)	1.4 HDi eco 70	8HX (DV4TD)	50	68	4	2	1.9.2001	-	D	
PEUGEOT	206 Hatchback (2A/C)	1.6 HDi 110	9HY (DV6TED4)	80	109	4	4	1.5.2004	-	D	
PEUGEOT	207 (WA_ WC_)	1.4 HDi	GENERAL MOTOR	50	68	4	4	1.2.2006	-	D	
PEUGEOT	207 (WA_ WC_)	1.6 HDi	9HY (DV6TED4)	80	109	4	4	1.2.2006	-	D	
PEUGEOT	307 (3A/C)	1.4 HDi	8HX (DV4TD)	50	68	4	2	1.10.2001	-	D	
PEUGEOT	307 (3A/C)	1.6 HDi 110	9HY (DV6TED4)	80	109	4	4	1.2.2004	-	D	



CITROËN - PEUGEOT

Stock No: 5020

Brand	Model	Motorization	Engine	Kw	Hip	Cylinders	Valves	From Date	To Date	Fuel	OEM
CITROËN	XANTIA (X1)	1.8 16V	LFY (XU7JP4)	81	110	4	4	01.06.1995	01.01.1998	P	0515K6
CITROËN	XANTIA (X1)	2.0 16V	RFT (XU10J4Z)	110	150	4	4	01.06.1994	01.01.1998	P	9624345280
CITROËN	XM (Y3)	2.0	RFZ (XU10J2)	89	121	4	2	01.05.1989	01.06.1994	P	
CITROËN	XSARA (N1)	1.8 16V	LFY (XU7JP4)	81	110	4	4	01.04.1997	01.09.2000	P	
CITROËN	XSARA (N1)	2.0 16V	RFS (XU10JAR5)	120	163	4	4	01.04.1997	01.09.2000	P	
CITROËN	ZX (N2)	1.8 16V	LFY (XU7JP4)	81	110	4	4	01.01.1995	01.06.1997	P	
CITROËN	ZX (N2)	2.0 16V	RFS (XU10JAR5)	120	163	4	4	01.05.1995	01.06.1997	P	
PEUGEOT	306 (78, N3, N5)	1.8 16V	LFY (XU7JP4)	81	110	4	4	01.03.1997	01.05.2001	P	
PEUGEOT	306 (78, N3, N5)	2.0	RFV (XU10JAR)	97	132	4	4	01.03.1997	01.05.2001	P	
PEUGEOT	405 (8B)	1.8 16V	LFY (XU7JP4)	81	110	4	4	01.11.1995	01.10.2000	P	
PEUGEOT	405 (8B)	2.0 16V	RFV (XU10JAR)	97	132	4	4	01.11.1995	01.05.2004	P	
PEUGEOT	505 (6B)	2.0 16V	RFV (XU10JAR)	97	132	4	4	01.07.1994	01.03.1999	P	
PEUGEOT	505 (221)	2.0 16V	RFV (XU10JAR)	97	132	4	4	01.05.1995	01.09.2000	P	



Stock No: 5021

Brand	Model	Motorization	Engine	Kw	Hip	Cylinders	Valves	From Date	To Date	Fuel	OEM
CITROËN	AX (2A_)	1.5 D	VJZ (TU05)	43	56	4	2	1.8.1994	1.12.1997	D	0515L6
CITROËN	SAXO (S0, S1)	1.5 D	VJY (TU05)	40	54	4	2	1.9.1996	1.9.2003	D	
CITROËN	SAXO (S0, S1)	1.5 D	VJZ (TU05)	42	57	4	2	1.9.1996	1.6.2001	D	
CITROËN	XSARA (N1)	1.5 D	VJZ (TU05)	42	57	4	2	1.4.1997	1.9.2000	D	
PEUGEOT	106 I (1A, 1C)	1.5 D	VJY (TU05)	40	54	4	2	1.6.1994	1.4.1996	D	
PEUGEOT	106 II (1)	1.5 D	VJY (TU05)	40	55	4	2	1.5.1996	-	D	



CITROEN - PEUGEOT

CITROEN - PEUGEOT

Stock No: 3031

Stock No: 5009

Brand	Model	Motorization	Engine	Kw	Hp	Cylinders	Valves	From Date	To Date	Fuel	OEM
CITROEN	JUMPER Bus	2.2 HDi 120	GENERAL MOTOR	88	120	4	4	01.04.2006	-	D	0515T1
PEUGEOT	BOXER Bus	2.2 HDi 120	GENERAL MOTOR	88	120	4	4	01.04.2006	-	D	

Brand	Model	Motorization	Engine	Kw	Hp	Cylinders	Valves	From Date	To Date	Fuel	OEM
CITROEN	Jumper 11Q	2.8 HDi	8140-435	93	127	4	2	01.09.2000	01.12.2001	D	0515N2
CITROEN	Jumper 14Q	2.8 HDi	F28TDCR	93	127	4	2	01.01.2002	01.06.2006	D	0515N8
CITROEN	Jumper 15Q	2.8 HDi	8140-435	93	127	4	2	01.09.2000	01.12.2001	D	0515P3
CITROEN	Jumper 18Q	2.8 HDi	F28TDCR	93	127	4	2	01.01.2002	01.06.2006	D	0515P9
CITROEN	Jumper 18Q	2.8 HDi	F28TDCR	93	127	4	2	01.01.2002	01.06.2006	D	
CITROEN	Jumper	2.8 HDi	8140-435	93	127	4	2	01.09.2000	01.12.2001	D	
CITROEN	Jumper	2.8 HDi	8140-63	64	87	4	2	01.06.1999	01.12.2001	D	
CITROEN	Jumper 33MH	2.8 HDi	8140-43	90	122	4	2	01.06.1999	01.12.2001	D	
CITROEN	Jumper 35L	2.8 HDi	F28TDCR	107	146	4	2	01.04.2004	01.06.2006	D	
CITROEN	Jumper 35LH	2.8 HDi	F28TDCR	107	146	4	2	01.04.2004	01.06.2006	D	
CITROEN	Jumper 35MH	2.8 HDi	F28TDCR	107	146	4	2	01.04.2004	01.06.2006	D	
CITROEN	Relay 10Q	2.8 HDi	F28TDCR	107	146	4	2	01.04.2004	01.06.2006	D	
CITROEN	Relay 14Q	2.8 HDi	8140-435	93	127	4	2	01.09.2000	01.12.2001	D	
CITROEN	Relay 15Q	2.8 HDi	8140-435	93	127	4	2	01.09.2000	01.12.2001	D	
CITROEN	Relay 18Q	2.8 HDi	F28TDCR	93	127	4	2	01.01.2002	01.06.2006	D	
CITROEN	Relay 18Q	2.8 HDi	F28TDCR	93	127	4	2	01.01.2002	01.06.2006	D	
CITROEN	Boxer 10Q	2.8 HDi	8140-435	93	127	4	2	01.09.2000	01.12.2001	D	
PEUGEOT	Boxer 11Q	2.8 HDi	8140-435	93	127	4	2	01.09.2000	01.12.2001	D	
PEUGEOT	Boxer 14Q	2.8 HDi	F28TDCR	93	127	4	2	01.01.2002	01.06.2006	D	
PEUGEOT	Boxer 14Q	2.8 HDi	8140-63	64	87	4	2	01.06.1999	01.12.2001	D	
PEUGEOT	Boxer 15Q	2.8 HDi	8140-435	93	127	4	2	01.09.2000	01.12.2001	D	
PEUGEOT	Boxer 18Q	2.8 HDi	F28TDCR	93	127	4	2	01.01.2002	01.06.2006	D	
PEUGEOT	Boxer 18Q	2.8 HDi	F28TDCR	93	127	4	2	01.01.2002	01.06.2006	D	
PEUGEOT	Boxer	2.8 HDi	8140-435	93	127	4	2	01.09.2000	01.12.2001	D	
PEUGEOT	Boxer 330C	2.8 HDi	8140-45	93	127	4	2	01.06.1999	01.12.2001	D	
PEUGEOT	Boxer 330C	2.8 HDi	F28TDCR	93	127	4	2	01.04.2004	01.08.2005	D	
PEUGEOT	Boxer 330C	2.8 HDi	F28TDCR	107	146	4	2	01.04.2004	01.06.2006	D	
PEUGEOT	Boxer 330CS	2.8 HDi	F28TDCR	93	127	4	2	01.04.2004	01.08.2005	D	
PEUGEOT	Boxer 330L	2.8 HDi	F28TDCR	107	146	4	2	01.04.2004	01.06.2006	D	
PEUGEOT	Boxer 330LH	2.8 HDi	F28TDCR	107	146	4	2	01.04.2004	01.06.2006	D	
PEUGEOT	Boxer 330M 15Q	2.8 HDi	F28TDCR	107	146	4	2	01.04.2004	01.06.2006	D	
PEUGEOT	Boxer 330M	2.8 HDi	F28TDCR	93	127	4	2	01.01.2002	01.06.2006	D	
PEUGEOT	Boxer 330MH	2.8 HDi	F28TDCR	107	146	4	2	01.04.2004	01.06.2006	D	
PEUGEOT	Boxer 330MH	2.8 HDi	F28TDCR	93	127	4	2	01.04.2004	01.06.2006	D	
PEUGEOT	Boxer 350C	2.8 HDi	F28TDCR	107	146	4	2	01.04.2004	01.06.2006	D	
PEUGEOT	Boxer 350CS	2.8 HDi	F28TDCR	107	146	4	2	01.04.2004	01.06.2006	D	
PEUGEOT	Boxer 350L	2.8 HDi	F28TDCR	107	146	4	2	01.04.2004	01.06.2006	D	
PEUGEOT	Boxer 350LH	2.8 HDi	F28TDCR	107	146	4	2	01.04.2004	01.06.2006	D	
PEUGEOT	Boxer 350LH	2.8 HDi	F28TDCR	107	146	4	2	01.04.2004	01.06.2006	D	
PEUGEOT	Boxer 350LH	2.8 HDi	F28TDCR	107	146	4	2	01.04.2004	01.06.2006	D	
PEUGEOT	Boxer 350LH	2.8 HDi	F28TDCR	107	146	4	2	01.04.2004	01.06.2006	D	
PEUGEOT	Boxer 350M	2.8 HDi	F28TDCR	107	146	4	2	01.04.2004	01.06.2006	D	
PEUGEOT	Boxer 350M	2.8 HDi	F28TDCR	93	127	4	2	01.04.2004	01.06.2006	D	
PEUGEOT	Boxer 350MH	2.8 HDi	F28TDCR	107	146	4	2	01.04.2004	01.06.2006	D	
PEUGEOT	Boxer 350MH	2.8 HDi	F28TDCR	93	127	4	2	01.04.2004	01.06.2006	D	
PEUGEOT	Boxer 350MH	2.8 HDi	F28TDCR	107	146	4	2	01.04.2004	01.06.2006	D	
PEUGEOT	Boxer 350MH	2.8 HDi	F28TDCR	107	146	4	2	01.04.2004	01.06.2006	D	

Stock No: 5022

Brand	Model	Motorization	Engine	Kw	Hp	Cylinders	Valves	From Date	To Date	Fuel	OEM
CITROEN	BERLINGO (MF)	1.6 16V (MFRFU)	NFU (TUSJP4)	80	109	4	4	01.10.2000	-	P	0515N0
CITROEN	C2 (JM_)	1.6	NFU (TUSJP4)	80	109	4	4	01.09.2003	-	P	0515P1
CITROEN	C3 (FC_)	1.4 16V	KFU (ETSJ4)	65	88	4	4	01.12.2003	-	P	0515P5
CITROEN	C3 (FC_)	1.6 16V	NFU (TUSJP4)	80	109	4	4	01.02.2002	-	P	0515R8
CITROEN	C3 Plurifit (PB_)	1.6	NFU (TUSJP4)	80	109	4	4	01.05.2003	-	P	0515S1
CITROEN	C4 (LC_)	1.4 16V	KFU (ETSJ4)	65	88	4	4	01.11.2004	-	P	9650653380
CITROEN	C4 (LC_)	1.6 16V	NFU (TUSJP4)	80	109	4	4	01.11.2004	-	P	9650653380
CITROEN	XSARA (N1)	1.6 16V	NFU (TUSJP4)	80	109	4	4	01.09.2000	01.03.2005	P	
PEUGEOT	1007 (KM_)	1.4 16V	KFU (ETSJ4)	65	88	4	4	01.10.2005	-	P	
PEUGEOT	1007 (KM_)	1.6 16V	NFU (TUSJP4)	80	109	4	4	01.04.2005	-	P	
PEUGEOT	206 Hatchback (2A/C)	1.4 16V	KFU (ETSJ4)	65	88	4	4	01.10.2003	-	P	
PEUGEOT	206 Hatchback (2A/C)	1.6 16V	NFU (TUSJP4)	80	109	4	4	01.12.2000	-	P	
PEUGEOT	207 (WA_ WC_)	1.4 16V	KFU (ETSJ4)	65	88	4	4	01.02.2006	-	P	
PEUGEOT	207 (WA_ WC_)	1.6 16V	NFU (TUSJP4)	80	109	4	4	01.02.2006	-	P	
PEUGEOT	307 (3A/C)	1.4 16V	KFU (ETSJ4)	65	88	4	4	01.11.2003	-	P	
PEUGEOT	307 (3A/C)	1.6 16V	NFU (TUSJP4)	80	109	4	4	01.08.2000	-	P	
PEUGEOT	PARTNER CombiSpace (5F)	1.6 16V	NFU (TUSJP4)	80	109	4	4	01.07.2001	-	P	



CITROEN - PEUGEOT

CITROEN - PEUGEOT

Stock No: 5014

Stock No: 3026

Brand	Model	Motorization	Engine	Kw	Hip	Cylinders	Valves	From Date	To Date	Fuel	DEM
CITROEN	C4 (LC_)	2.0 HDI	DW10BTE4	100	136	4	4	01.11.2004	-	D	051576
CITROEN	C4 Coupe (LA_)	2.0 HDI	DW10BTE4	103	140	4	4	01.11.2004	-	D	051579
CITROEN	C4 Picasso (LD_)	2.0 HDI	RHH	120	163	4	4	01.02.2007	-	D	051506
CITROEN	C5 (RC_)	2.0 HDI	DW10BTE4	100	136	4	4	01.08.2004	-	D	051508
CITROEN	C5 Break (TD_)	2.0 HDI	RHH	120	163	4	4	01.02.2008	-	D	
CITROEN	C8 (EA_EB_)	2.0 HDI	RHK-RHR	88	120	4	4	01.07.2007	-	D	
CITROEN	JUMPY Kasten	2.0 HDI	RHK-RHR	100	136	4	4	01.01.2007	-	D	
CITROEN	307	2.0 HDI	RHR-RHH	100	136	4	4	01.08.2000	-	D	
CITROEN	308	2.0 HDI	RHR-RHH	100	136	4	4	01.09.2007	-	D	
CITROEN	407	2.0 HDI	RHR-RHH	100	136	4	4	01.05.2004	-	D	
CITROEN	508	2.0 HDI	RHR-RHH	100	136	4	4	01.11.2010	-	D	
CITROEN	607	2.0 HDI	RHR-RHH	100	136	4	4	01.01.2000	-	D	
CITROEN	807	2.0 HDI	RHR-RHH	100	136	4	4	01.06.2002	-	D	
CITROEN	3008	2.0 HDI	RHR-RHH	100	136	4	4	01.06.2009	-	D	
CITROEN	5008	2.0 HDI	RHR-RHH	100	136	4	4	01.09.2009	-	D	
CITROEN	EXPERT Tepee (VF3V_)	2.0 HDI	RHR-RHH	100	136	4	4	01.01.2007	-	D	

Brand	Model	Motorization	Engine	Kw	Hip	Cylinders	Valves	From Date	To Date	Fuel	DEM
CITROEN	C2 (JM_)	1.4 HDI	8HX (DV4TD)	50	68	4	2	01.09.2003	-	D	051573
CITROEN	C3 (FC_)	1.4 HDI	8HX (DV4TD)	50	68	4	2	01.02.2002	-	D	
CITROEN	C3 (FC_)	1.6 16V HDI	9HX(DV6ATED4)	66	90	4	4	01.10.2006	-	D	
CITROEN	C3 (FC_)	1.6 16V HDI	DV6TED4	80	109	4	4	01.09.2005	-	D	
CITROEN	C3 Flanel (HB_)	1.4 HDI	8HX (DV4TD)	50	68	4	2	01.04.2004	-	D	
CITROEN	C4 (LC_)	1.6 HDI	9HX(DV6ATED4)	66	90	4	4	01.11.2004	-	D	
CITROEN	C4 (LC_)	1.6 HDI	DV6TED4	80	109	4	4	01.11.2004	-	D	
CITROEN	C4 Coupe (LA_)	1.6 HDI	9HX(DV6ATED4)	66	90	4	4	01.11.2004	-	D	
CITROEN	C4 Coupe (LA_)	1.6 HDI	DV6TED4	80	109	4	4	01.11.2004	-	D	
CITROEN	C4 Grand Picasso (UA_)	1.6 HDI	9HZ-DV6TED4	80	109	4	4	01.10.2006	-	D	
CITROEN	C4 Picasso (LD_)	1.6 HDI	9HZ-DV6TED4	80	109	4	4	01.02.2007	-	D	
CITROEN	C5 (RC_)	1.6 HDI (RC9HZB)	DV6TED4	80	109	4	4	01.09.2004	-	D	
CITROEN	C5 Break (RE_)	1.6 HDI (RE9HZB)	DV6TED4	80	109	4	4	01.09.2004	-	D	
CITROEN	JUMPY	1.6 HDI 90	GENERAL MOTOR	66	90	4	2	01.01.2007	-	D	
CITROEN	JUMPY Box	1.6 HDI 90	GENERAL MOTOR	66	90	4	2	01.01.2007	-	D	
CITROEN	XSARA PICASSO (V68)	1.6 HDI	GENERAL MOTOR	66	90	4	2	01.09.2005	-	D	
PEUGEOT	1007 (KM_)	1.6 HDI	9HZ (DV6TED4)	80	109	4	4	01.06.2007	-	D	
PEUGEOT	206 CC (2D)	1.6 HDI 110	9HZ (DV6TED4)	80	109	4	4	01.04.2005	-	D	
PEUGEOT	206 Hatchback (2A/C)	1.4 HDI esp 70	8HX (DV4TD)	50	68	4	2	01.09.2001	-	D	
PEUGEOT	206 Hatchback (2A/C)	1.6 HDI 110	9HY (DV6TED4)	80	109	4	4	01.05.2004	-	D	
PEUGEOT	206 SW (2EK)	1.4 HDI	8HX (DV4TD)	50	68	4	2	01.07.2002	-	D	
PEUGEOT	206 SW (2EK)	1.6 HDI 110	9HZ (DV6TED4)	80	109	4	4	01.05.2004	-	D	
PEUGEOT	207 (WA_WC_)	1.4 HDI	GENERAL MOTOR	50	68	4	4	01.02.2006	-	D	
PEUGEOT	207 (WA_WC_)	1.6 HDI	9HX(DV6ATED4)	66	90	4	4	01.02.2006	-	D	
PEUGEOT	207 (WA_WC_)	1.6 HDI	9HY (DV6TED4)	80	109	4	4	01.02.2006	-	D	
PEUGEOT	207 CC (WD_)	1.6 HDI	9HZ (DV6TED4)	80	109	4	4	01.02.2007	-	D	
PEUGEOT	207 SW (WK_)	1.6 HDI	9HX(DV6ATED4)	66	90	4	4	01.06.2007	-	D	
PEUGEOT	207 SW (WK_)	1.6 HDI	9HZ (DV6TED4)	80	109	4	4	01.06.2007	-	D	
PEUGEOT	307 (3A/C)	1.6 HDI	9HX (DV6ATED4)	66	90	4	4	01.04.2005	-	D	
PEUGEOT	307 (3A/C)	1.6 HDI 110	9HY (DV6TED4)	80	109	4	4	01.02.2004	-	D	
PEUGEOT	307 Break (3E)	1.6 HDI	9HX (DV6ATED4)	66	90	4	4	01.04.2005	-	D	
PEUGEOT	307 Break (3E)	1.6 HDI 110	9HY (DV6TED4)	80	109	4	4	01.02.2004	-	D	
PEUGEOT	307 SW (3H)	1.6 HDI 110	9HY (DV6TED4)	80	109	4	4	01.02.2004	-	D	
PEUGEOT	308 (4A_4C_)	1.6 HDI	9HZ (DV6TED4)	80	109	4	4	01.09.2007	-	D	
PEUGEOT	308 (4A_4C_)	1.6 HDI	GENERAL MOTOR	66	90	4	2	01.09.2007	-	D	
PEUGEOT	EXPERT Box (VF3A_VF3U_VF3X_)	1.6 HDI 90	GENERAL MOTOR	66	90	4	4	01.01.2007	-	D	
PEUGEOT	EXPERT Flatbed / Chassis	1.6 HDI 90	GENERAL MOTOR	66	90	4	4	01.01.2007	-	D	
PEUGEOT	EXPERT Tepee (VF3V_)	1.6 HDI 90	GENERAL MOTOR	66	90	4	4	01.01.2007	-	D	
PEUGEOT	PARTNER Box (5)	1.6 HDI 75	GENERAL MOTOR	55	75	4	4	01.02.2006	-	D	
PEUGEOT	PARTNER Box (5)	1.6 HDI 90	9HX (DV6ATED4)	66	90	4	4	01.02.2006	-	D	
PEUGEOT	PARTNER Combispacer (5F)	1.6 HDI 75	GENERAL MOTOR	55	75	4	4	01.02.2006	-	D	
PEUGEOT	PARTNER Combispacer (5F)	1.6 HDI 90	9HX (DV6ATED4)	66	90	4	4	01.02.2006	-	D	



CITROEN - PEUGEOT

CITROEN - PEUGEOT

Stock No: 5023

Stock No: 5012

Brand	Model	Motorization	Engine	Kw	Hip	Cylinders	Valves	From Date	To Date	Fuel	DEM
CITROEN	C2 (JM_)	1.4 16V	KFU (ETSJ4)	65	90	4	4	01.06.2006	-	P	0515R4
CITROEN	C2 (JM_)	41061	NFU (TUSJP4)	80	109	4	4	01.09.2003	-	P	0515P7
CITROEN	C2 (JM_)	1.6 VTS	NFS (TUSJP4S)	90	122	4	4	01.01.2005	-	P	515R6
CITROEN	C3 (FC_)	1.4 16V	KFU (ETSJ4)	65	88	4	4	01.12.2003	-	P	
CITROEN	C3 (FC_)	1.6 16V	NFU (TUSJP4)	80	109	4	4	01.02.2002	-	P	
CITROEN	C4 (LC_)	1.4 16V	KFU (ETSJ4)	65	88	4	4	01.11.2004	-	P	
CITROEN	C4 (LC_)	1.6 16V	NFU (TUSJP4)	80	109	4	4	01.11.2004	-	P	
CITROEN	C4 (LC_)	1.6 16V Bio-Flex	NFU (TUSJP4)	80	109	4	4	01.09.2007	-	P	
CITROEN	C4 Coupe (LA_)	1.4 16V	KFU (ETSJ4)	65	88	4	4	01.11.2004	-	P	
CITROEN	C4 Coupe (LA_)	1.6 16V	NFU (TUSJP4)	80	109	4	4	01.11.2004	-	P	
PEUGEOT	307 (3A/C)	1.4 16V	KFU (ETSJ4)	65	88	4	4	01.11.2003	-	P	
PEUGEOT	307 (3A/C)	1.6 16V	NFU (TUSJP4)	80	109	4	4	01.08.2000	-	P	
PEUGEOT	307 Break (3E)	1.4 16V	KFU (ETSJ4)	65	88	4	4	01.11.2003	-	P	
PEUGEOT	307 Break (3E)	1.6 16V	NFU (TUSJP4)	80	109	4	4	01.03.2002	-	P	
PEUGEOT	307 SW (3H)	1.4 16V	KFU (ETSJ4)	65	88	4	4	01.11.2003	-	P	

Brand	Model	Motorization	Engine	Kw	Hip	Cylinders	Valves	From Date	To Date	Fuel	DEM
CITROEN	C5 (DC_)	2.0 HDi	RHY	66	90	4	2	01.03.2001	01.08.2004	D	0515R2
CITROEN	C5 (DC_)	2.0 HDi	RHZ	80	109	4	2	01.03.2001	01.08.2004	D	0515G4
CITROEN	C5 Break (DE_)	2.0 HDi	RHS	79	107	4	2	01.06.2001	01.08.2004	D	
CITROEN	C5 Break (DE_)	2.0 HDi	RHY	66	90	4	2	01.06.2001	01.08.2004	D	
CITROEN	C8 (EA_EB_)	2.0 HDi	RHW	79	107	4	4	01.07.2002	-	D	
CITROEN	C8 (EA_EB_)	2.2 HDi	4HW	94	128	4	4	01.07.2002	-	D	
CITROEN	JUMPY Box	1.9 D 70	WJZ	51	69	4	2	01.04.1998	-	D	
CITROEN	JUMPY Box	2.0 HDi 110	RHZ	80	109	4	2	01.01.2002	-	D	
CITROEN	JUMPY Box	2.0 HDi 95	RHX	69	94	4	2	01.10.1999	-	D	
PEUGEOT	206 Hatchback (2A/C)	2.0 HDi 90	RHY	66	90	4	2	01.12.1999	-	D	
PEUGEOT	307 (3A/C)	2.0 HDi 110	RHS	79	107	4	2	01.08.2000	-	D	
PEUGEOT	307 (3A/C)	2.0 HDi 90	RHY	66	90	4	2	01.08.2000	-	D	
PEUGEOT	406 (8B)	2.0 HDi 90	RHY	66	90	4	2	01.02.1999	01.05.2004	D	
PEUGEOT	406 Break (8E/F)	2.0 HDi 110	RHZ	80	109	4	2	01.02.1999	01.04.2004	D	
PEUGEOT	607 (9D,9U)	2.0 HDi	RHZ	80	109	4	2	01.05.2000	-	D	
PEUGEOT	607 (9D,9U)	2.2 HDi	4HX	98	133	4	4	01.02.2000	-	D	
PEUGEOT	607 (E)	2.0 HDi	RHW	79	107	4	4	01.06.2002	-	D	
PEUGEOT	607 (E)	2.2 HDi	4HX	94	128	4	4	01.06.2002	-	D	
PEUGEOT	EXPERT Box (122)	1.9 D 70	WJY	51	69	4	2	01.12.1998	-	D	
PEUGEOT	EXPERT Box (122)	2.0 HDi	RHX	69	94	4	2	01.07.2000	-	D	
PEUGEOT	EXPERT Box (122)	2.0 HDi	RHZ	80	109	4	2	01.07.2000	-	D	



Stock No: 5024

Brand	Model	Motorization	Engine	Kw	Hip	Cylinders	Valves	From Date	To Date	Fuel	DEM
CITROEN	JUMPER Box (230L)	2.5 D	T9A (DJ5)	63	86	4	2	1.3.1994	1.4.2002	D	0515H3
CITROEN	JUMPER Box (230L)	2.5 TD	T8A (DJ5T)	76	103	4	2	1.3.1994	1.4.2002	D	
CITROEN	JUMPER Box (230L)	2.5 TDI	THX (DJ5TED)	79	107	4	2	1.12.1996	1.11.2000	D	
CITROEN	XM (Y4)	2.5 TD	THY (DK5ATE)	95	129	4	3	1.5.1994	1.10.2000	D	
PEUGEOT	605 (6B)	2.5 Turbo Diesel	THY (DK5ATE)	95	129	4	3	1.7.1994	1.9.1999	D	
PEUGEOT	BOXER Box (230L)	2.5 D	T9A (DJ5)	63	86	4	2	1.3.1994	1.4.2002	D	
PEUGEOT	BOXER Box (230L)	2.5 TD	T8A (DJ5T)	76	103	4	2	1.3.1994	1.4.2002	D	
PEUGEOT	BOXER Box (230L)	2.5 TDI	THX (DJ5TED)	79	107	4	2	1.1.1997	1.4.2002	D	



CITROEN - PEUGEOT

Stock No: 5004

Brand	Model	Motorization	Engine	Kw	Hp	Cylinders	Valves	From Date	To Date	Fuel	DEM
CITROEN	EVASION (22, U6)	18	LFZ (XU7JP)	73	99	4	2	1.5.1997	1.7.2002	F	0515H6
CITROEN	SAXO (50, 51)	1.6 VTS	NFX (TU5JP4)	87	116	4	4	1.8.1996	1.9.2003	F	
CITROEN	XANTIA (X1)	1.8 I	LFZ (XU7JP)	74	101	4	2	1.3.1993	1.1.1998	F	
CITROEN	XANTIA (X1)	2.0 I	RFX (XU10JCC)	89	121	4	2	1.3.1993	1.1.1998	F	
CITROEN	XANTIA (X1)	2.0 Turbo	RGX (XU10J2TE)	108	147	4	2	1.8.1995	1.1.1998	F	
CITROEN	XSARA (N1)	1.8 I	LFX (XU7JB)	66	90	4	2	1.4.1997	1.9.2000	F	
CITROEN	XSARA (N1)	2.0 16V	RFV (XU10J4R)	97	132	4	4	1.7.1996	1.9.2000	F	
CITROEN	ZX (N2)	1.8 I	LFZ (XU7JP)	74	101	4	2	1.7.1992	1.6.1997	F	
PEUGEOT	106 II (1)	1.6 I	NFZ (TU5JP)	65	89	4	2	1.5.1996	-	F	
PEUGEOT	306 (7B, N3, N5)	1.8 ST	LFZ (XU7JP)	74	101	4	2	1.6.1994	1.5.2001	F	
PEUGEOT	306 (7B, N3, N5)	2.0 ST	RFX (XU10J2)	89	121	4	2	1.7.1994	1.5.2001	F	
PEUGEOT	406 II (4B)	18	LFZ (XU7JP)	74	101	4	2	1.8.1992	1.10.1995	F	
PEUGEOT	406 II (4B)	20	RFX (XU10J2)	89	121	4	2	1.8.1992	1.10.1995	F	
PEUGEOT	406 (5B)	2.0 Turbo	RGX (XU10J2TE)	108	147	4	2	1.4.1996	1.5.2004	F	
PEUGEOT	605 (5B)	2.0 Turbo	RGX (XU10J2TE)	108	147	4	2	1.7.1991	1.9.1999	F	



RENAULT - DACIA

Stock No: 5025

Brand	Model	Motorization	Engine	Kw	Hp	Cylinders	Valves	From Date	To Date	Fuel	DEM
RENAULT	LAGUNA (B56, B56_)	2.2 D (B56F/2)	G8T 706	61	83	4	3	1.11.2001	-	D	7700868731



Stock No: 2090

Brand	Model	Motorization	Engine	Kw	Hp	Cylinders	Valves	From Date	To Date	Fuel	DEM
RENAULT	CLIO I (B/C57_ 5,357_)	1.9 D (B/C/6576, B/C/657L)	F8Q 730	47	64	4	2	1.1.1991	1.9.1998	D	1230300QAN
RENAULT	CLIO I (B/C57_ 5,357_)	1.9 D	F8Q 678	40	54	4	2	1.1.1997	1.5.2001	D	7700107145
RENAULT	CLIO II (BBQ/1/2_ CBQ/1/2_)	1.9 D	F8Q 632	48	65	4	2	1.2.2000	1.5.2006	D	7700112999
RENAULT	CLIO II (BBQ/1/2_ CBQ/1/2_)	1.9 D (B/C80E)	F8Q 630	47	64	4	2	1.9.1998	-	D	7700724249
RENAULT	CLIO II Box (SBQ/1/2_)	1.9 D (SB0E)	F8Q 630	47	64	4	2	1.9.1998	-	D	7700864763
RENAULT	KANGOO (KCO/1_)	D 55 1.9 (KCOO)	F8Q 662	40	54	4	2	1.8.1997	-	D	8200396445
RENAULT	KANGOO (KCO/1_)	D 65 1.9 (KCOE, KCO2, KCOJ)	F8Q 630	47	64	4	2	1.8.1997	-	D	8200545437
RENAULT	KANGOO Express (FCO/1_)	D 55 1.9 (FCOO)	F8Q 662	40	54	4	2	1.8.1997	-	D	
RENAULT	KANGOO Express (FCO/1_)	D 65 1.9 (FCOE, FCO2, FCOJ)	F8Q 630	47	64	4	2	1.8.1997	-	D	
RENAULT	MEGANE I (BAQ/1_)	1.9 D Eco (B/SAOU, BAQA)	F8Q 620	47	64	4	2	1.1.1996	-	D	
RENAULT	MEGANE I Classic (LAQ/1_)	1.9 D (LAQA, LAQU)	F8Q 620	47	64	4	2	1.9.1996	-	D	
RENAULT	MEGANE I Classic (LAQ/1_)	1.9 dT (LACK, LADY)	F8Q 784	66	90	4	2	1.9.1996	-	D	
RENAULT	MEGANE I Classic (LAQ/1_)	1.9 TDI	F8Q 784	69	94	4	2	1.9.1996	-	D	
RENAULT	MEGANE I Grandtour (KAQ/1_)	1.9 D (KAQJ, KAOR)	F8Q 622	47	64	4	2	1.4.1999	-	D	
RENAULT	MEGANE Scenic (JAO/1_)	1.9 D (JAOJ)	F8Q 790	47	64	4	2	1.3.1997	1.9.1999	D	
RENAULT	MEGANE Scenic (JAO/1_)	1.9 dT (JAKK, JADY)	F8Q 784	66	90	4	2	1.1.1997	1.9.1999	D	
RENAULT	RAPID Box (F4Q_ G4Q_)	1.6 D (F4Q4)	F6M 720	40	55	4	2	1.3.1996	1.8.1998	D	
RENAULT	RAPID Box (F4Q_ G4Q_)	1.9 D (F4QF)	F8Q 640	40	54	4	2	1.9.1994	1.3.1998	D	
RENAULT	TRAFIC Box (TXX)	1.9 D	F8Q 606	44	60	4	2	1.6.1997	1.3.2001	D	
RENAULT	TRAFIC Bus (TXX)	1.9 D	F8Q 606	44	60	4	2	1.6.1997	1.3.2001	D	



RENAULT - DACIA

RENAULT - DACIA

Stock No: 5026

Brand	Model	Motorization	Engine	Kw	Hp	Cylinders	Valves	From Date	To Date	Fuel	OEM
RENAULT	LAGUNA I (B56_556_)	1.9 DCI	F9Q 718	79	107	4		01.11.1993	01.03.2001	D	7700113776
RENAULT	LAGUNA II (B60*1_)	1.9 DCI	F9Q 752	77	106	4		01.03.2001	-	D	7700115766
RENAULT	TRAFIC II Bus (JL)	1.9 DCI	F9Q 762	80	82	4		01.03.2001	-	D	8200079183
RENAULT	TRAFIC II Kasten (FL)	1.9 DCI	F9Q 760	80	82	4		01.03.2001	-	D	8200386446



Stock No: 2094

Brand	Model	Motorization	Engine	Kw	Hp	Cylinders	Valves	From Date	To Date	Fuel	OEM
RENAULT	ESPACE III (JEQ_)	2.0 (JE0A)	F3R 728	84	114	4	2	1.11.1996	1.10.2000	F	7700109260
RENAULT	LAGUNA (B56_556_)	2.0	F3R 611	80	109	4	2	1.3.1999	1.3.2001	F	8200458960
RENAULT	LAGUNA Grandtour (K98_)	2.0 (K56C/H)	F3R 722	83	113	4	2	1.9.1995	1.3.2001	F	
RENAULT	MEGANE I (BA0*1_)	2.0 I	F3R 750	80	109	4	2	1.9.1995	-	F	
RENAULT	MEGANE I (BA0*1_)	2.0 I (BA0G)	F3R 750	84	114	4	2	-	-	F	
RENAULT	MEGANE I Cabriolet (EA0*1_)	2.0 (EA0G)	F3R 750	84	114	4	2	-	-	F	
RENAULT	MEGANE I Cabriolet (EA0*1_)	2.0 I (EA0G)	F3R 791	80	109	4	2	-	-	F	
RENAULT	MEGANE I Classic (LA0*1_)	2.0 I	F3R 752	80	109	4	2	-	-	F	
RENAULT	MEGANE I Classic (LA0*1_)	2.0 I (LA07_LA0G)	F3R 750	84	114	4	2	-	-	F	
RENAULT	MEGANE I Coach (DA0*1_)	2.0 I	GENERAL MOTOR	80	109	4	2	1.3.1999	1.8.2003	F	
RENAULT	MEGANE I Coach (DA0*1_)	2.0 I (DA0G)	F3R 750	84	114	4	2	1.3.1996	1.8.2003	F	
RENAULT	MEGANE Scenic (JA0*1_)	2.0 I (JA0G)	F3R 750	84	114	4	2	1.1.1997	1.9.1999	F	

Stock No: 2095

Brand	Model	Motorization	Engine	Kw	Hp	Cylinders	Valves	From Date	To Date	Fuel	OEM
RENAULT	CLIO II (B80*1/2_ CB0*1/2_)	1.4 16V (B/CB0F)	K4J 700	72	98	4	4	01.08.2000	-	P	8200185800
RENAULT	CLIO II (B80*1/2_ CB0*1/2_)	1.6 16V (CB0T, CB0H)	K4M 708	79	107	4	4	01.09.1998	-	P	8200392697
RENAULT	CLIO II (B80*1/2_ CB0*1/2_)	1.5 dCi	K9K 712	74	100	4	2	01.01.2004	-	D	1230300QAU
RENAULT	CLIO II (B80*1/2_ CB0*1/2_)	1.5 dCi (B/CB07)	K9K 700	48	65	4	2	01.06.2001	-	D	
RENAULT	CLIO II (B80*1/2_ CB0*1/2_)	1.5 dCi (B/CB08)	K9K 702	60	82	4	2	01.06.2001	-	D	
RENAULT	CLIO III (BR0*1, CR0*1)	1.4 16V	K4J 780	72	98	4	4	01.06.2008	-	F	
RENAULT	CLIO III (BR0*1, CR0*1)	1.6 16V	K4M 800	82	112	4	4	01.06.2008	-	F	
RENAULT	CLIO III (BR0*1, CR0*1)	1.6 16V	K4M 804	65	88	4	4	01.06.2008	-	F	
RENAULT	CLIO III (BR0*1, CR0*1)	1.5 dCi	K9K 764	78	106	4	2	01.06.2008	-	D	
RENAULT	CLIO III (BR0*1, CR0*1)	1.5 dCi	K9K 766	63	86	4	2	01.06.2008	-	D	
RENAULT	CLIO III (BR0*1, CR0*1)	1.5 dCi (C/BR1G)	K9K 768	50	68	4	2	01.06.2008	-	D	
RENAULT	GRAND SCENIC II (JM0*1_)	1.6	K4M 761	83	113	4	4	01.04.2004	-	F	
RENAULT	KANGOO (KC0*1_)	1.5 dCi	K9K 704	42	57	4	2	01.07.2003	-	D	
RENAULT	KANGOO (KC0*1_)	1.5 dCi (KC07)	K9K 700	48	65	4	2	01.12.2001	-	D	
RENAULT	KANGOO (KC0*1_)	1.5 dCi (KC08, KC09)	K9K 702	60	82	4	2	01.07.2002	-	D	
RENAULT	MEGANE II (BM0*1_ CM0*1_)	1.6 16V	K4M 760	82	112	4	4	01.01.2007	-	F	
RENAULT	MEGANE II Coupé-Cabriolet (EM0*1_)	1.6 16V	K4M 760	82	112	4	4	01.01.2007	-	F	
RENAULT	MEGANE II Estate (KM0*1_)	1.6 16V	K4M 760	82	112	4	4	01.01.2007	-	F	
RENAULT	MEGANE II Saloon (LM0*1_)	1.6 16V	K4M 812	82	112	4	4	01.01.2007	-	F	
RENAULT	MEGANE II (BM0*1_ CM0*1_)	1.5 dCi	K9K 729	74	101	4	2	01.10.2003	-	D	
RENAULT	MEGANE II (BM0*1_ CM0*1_)	1.5 dCi (BMOF, CM0F)	K9K 722	60	82	4	2	01.11.2002	-	D	
RENAULT	MEGANE II (BM0*1_ CM0*1_)	1.6 16V (BMOG, CM0G)	K4M 760	83	113	4	4	01.11.2002	-	F	
RENAULT	MEGANE II Estate (KM0*1_)	1.5 dCi	K9K 722	60	82	4	2	01.08.2003	-	D	
RENAULT	MEGANE II Estate (KM0*1_)	1.5 dCi	K9K 729	74	101	4	2	01.02.2004	-	D	
RENAULT	MEGANE II Estate (KM0*1_)	1.5 dCi	K9K 722	60	82	4	2	01.09.2003	-	D	
RENAULT	MEGANE II Saloon (LM0*1_)	1.5 dCi	K9K 729	74	101	4	2	01.02.2004	-	D	
RENAULT	MODUS (FJ0*1_)	1.4 (JF01, JF0J)	K4J 770	72	98	4	4	01.12.2004	-	F	
RENAULT	MODUS (FJ0*1_)	1.6	K4M 792	65	88	4	4	01.12.2004	-	F	
RENAULT	MODUS (FJ0*1_)	1.6 (JF0B)	K4M 790	82	112	4	4	01.12.2004	-	F	
RENAULT	SCENIC II (JM0*1_)	1.4 (JM0B, JM0H, JM1A)	K4J 730	72	98	4	4	01.06.2003	-	F	
RENAULT	SCENIC II (JM0*1_)	1.6 (JM0C, JM0J, JM1B)	K4M 761	83	113	4	4	01.06.2003	-	F	
RENAULT	SCENIC II (JM0*1_)	1.6 16V	K4M 812	82	112	4	4	01.01.2007	-	F	
RENAULT	SCENIC II (JM0*1_)	1.5 dCi (JM02, JM13)	K9K 728	74	101	4	2	01.11.2003	-	D	
RENAULT	SCENIC II (JM0*1_)	1.5 dCi (JM0F)	K9K 722	60	82	4	2	01.06.2003	-	D	



RENAULT - DACIA

Stock No: 2093

Brand	Model	Motorization	Engine	Kw	Hp	Cylinders	Valves	From Date	To Date	Fuel	OEM
RENAULT	CLIO II (BB01/2_, CB01/2_)	1.4 16V (B/CB0L)	K4J 712	70	95	4	4	1.10.1999	1.08.2000	P	7700108321
RENAULT	CLIO II (BB01/2_, CB01/2_)	1.4 16V (B/CB0P)	K4J 700	72	98	4	4	1.8.2000	-	P	8200313231
RENAULT	CLIO II (BB01/2_, CB01/2_)	1.6 16V (CB0T, CB0H)	K4M 708	79	107	4	4	1.9.1998	-	P	8200392883
RENAULT	KANGOO (KD01_)	1.5 16V	K4M 750	70	95	4	4	1.6.2001	-	P	
RENAULT	KANGOO (KD01_)	1.5 16V 4x4 (KCOF, KCDS, KCDL)	K4M 750	70	95	4	4	1.10.2001	-	P	
RENAULT	KANGOO (KD01_)	1.5 16V bivalent	GENERAL MOTOR	60	82	4	4	1.6.2006	-	Bi-Fuel	
RENAULT	KANGOO Express (FC01_)	1.5 16V	K4M 762	70	95	4	4	1.10.2001	-	P	
RENAULT	KANGOO Express (FC01_)	1.5 16V 4x4 (FC0L, FC0P, FC0G)	K4M 750	70	95	4	4	1.10.2001	-	P	
RENAULT	LAGUNA (B56_, B56L)	1.6 16V (B56B, B561)	K4M 720	79	107	4	4	1.11.1997	1.3.2001	P	
RENAULT	LAGUNA Grandtour (K55_)	1.5 16V (K55B)	K4M 720	79	107	4	4	1.11.1997	1.3.2001	P	
RENAULT	LAGUNA II (BG01_)	1.6 16V	K4M 716	82	112	4	4	1.2.2006	-	P	
RENAULT	LAGUNA II (BG01_)	1.6 16V (B90A, B90L)	K4M 710	79	107	4	4	1.3.2001	-	P	
RENAULT	LAGUNA II Grandtour (KG01_)	1.6 16V	K4M 716	82	112	4	4	1.2.2006	-	P	
RENAULT	LAGUNA II Grandtour (KG01_)	1.6 16V (KG0A, KG0L)	K4M 710	79	107	4	4	1.3.2001	-	P	
RENAULT	MEGANE I (BA01_)	1.4 16V (BA0D, BA1H, BA0W, BA10)	K4J 714	70	95	4	4	1.3.1999	-	P	
RENAULT	MEGANE I (BA01_)	1.6 16V (BA11, BA04, BA0B, BA1J)	K4M 700	79	107	4	4	1.3.1999	-	P	
RENAULT	MEGANE I Cabriolet (EA01_)	1.4 16V (EA0D, EA1H, EA0W, EA10)	K4J 714	70	95	4	4	1.3.1999	-	P	
RENAULT	MEGANE I Cabriolet (EA01_)	1.6 16V (EA0B, EA04, EA11)	K4M 700	79	107	4	4	1.3.1999	-	P	
RENAULT	MEGANE I Classic (LA01_)	1.4 16V (LA0D, LA1H, LA0W, LA10)	K4J 714	70	95	4	4	1.3.1999	-	P	
RENAULT	MEGANE I Classic (LA01_)	1.6 16V (LA04, LA11, LA0B, LA10, LA1J)	K4M 700	79	107	4	4	1.3.1999	-	P	
RENAULT	MEGANE I Coach (DA01_)	1.4 16V (DA0D, DA1H, DA0W, DA10)	K4J 714	70	95	4	4	1.3.1999	1.3.2003	P	
RENAULT	MEGANE I Coach (DA01_)	1.6 16V (DA0B, DA04, DA11)	K4M 700	79	107	4	4	1.3.1999	1.8.2003	P	
RENAULT	MEGANE I Grandtour (KA01_)	1.4 16V (KA0D, KA1H, KA0W, KA10)	K4J 714	70	95	4	4	1.3.1999	-	P	
RENAULT	MEGANE I Grandtour (KA01_)	1.6 16V (KA0B, KA04, KA11)	K4M 700	79	107	4	4	1.3.1999	-	P	
RENAULT	SCENIC I (JA01_)	1.4 16V (JA0D, JA1H, JA0W, JA10)	K4J 714	70	95	4	4	1.9.1999	1.8.2003	P	
RENAULT	SCENIC I (JA01_)	1.6 16V (JA0B, JA04, JA11)	K4M 700	79	107	4	4	1.9.1999	1.8.2003	P	
RENAULT	THALIA (LB01/2_)	1.4 16V	K4J 712	72	98	4	4	1.8.2000	-	P	



RENAULT - DACIA

Stock No: 5027

Brand	Model	Motorization	Engine	Kw	Hp	Cylinders	Valves	From Date	To Date	Fuel	OEM
RENAULT	MASTER II Box (FD)	2.5 dCi 120	GSU 720	84	115	4	4	01.10.2001	-	D	8200267867
RENAULT	MASTER II Bus (JD/ND)	2.5 dCi 120	GSU 720	84	115	4	4	01.10.2001	-	D	
RENAULT	MASTER II Flatbed / Chassis (ED/HQ/UD)	2.5 dCi 120	GSU 720	84	115	4	4	01.10.2001	-	D	



Stock No: 5028

Brand	Model	Motorization	Engine	Kw	Hp	Cylinders	Valves	From Date	To Date	Fuel	OEM
RENAULT	ESPACE IV (JK01_)	2.2 dCi (JK07)	G9T 645	102	139	4	4	01.02.2006	-	D	8200555549
RENAULT	ESPACE IV (JK01_)	2.2 dCi (JK0H) G9T	742,697 743	110	150	4	4	01.11.2002	-	D	8200207435
RENAULT	ESPACE IV (JK01_)	2.2 dCi (JK0H) G9T	742,697 743	110	150	4	4	01.11.2002	-	D	
RENAULT	MASTER III Box (HD, FD)	2.5 dCi	GSU 632	107	146	4	4	01.08.2006	-	D	
RENAULT	MASTER III Box (HD, FD)	2.5 dCi	GSU 650	88	120	4	4	01.08.2006	-	D	
RENAULT	MASTER III Box (HD, FD)	2.5 dCi	GSU 754	74	101	4	4	01.08.2006	-	D	
RENAULT	MASTER III Bus (JD)	2.5 dCi	GSU 632	107	146	4	4	01.08.2006	-	D	
RENAULT	MASTER III Bus (JD)	2.5 dCi	GSU 650	88	120	4	4	01.08.2006	-	D	
RENAULT	MASTER III Bus (JD)	2.5 dCi	GSU 754	74	101	4	4	01.08.2006	-	D	
RENAULT	MASTER III Flatbed / Chassis (ED, UD)	2.5 dCi	GSU 632	107	146	4	4	01.08.2006	-	D	
RENAULT	MASTER III Flatbed / Chassis (ED, UD)	2.5 dCi	GSU 650	88	120	4	4	01.08.2006	-	D	
RENAULT	MASTER III Flatbed / Chassis (ED, UD)	2.5 dCi	GSU 754	74	101	4	4	01.08.2006	-	D	



RENAULT - DACIA

Stock No: 5029

Brand	Model	Motorization	Engine	Kw	Hp	Cylinders	Valves	From Date	To Date	Fuel	OEM
RENAULT	CLIO III (BR01, CR01)	1.5 dCi (BR17, CR17)	K9K 766	63	86	4	2	01.06.2005	-	D	8200552236
RENAULT	KANGOO (KW01_)	1.5 dCi (KW0C, KW0F)	K9K 804	76	103	4	2	01.02.2008	-	D	8200699517
RENAULT	KANGOO Express (FW01_)	1.5 dCi (FW0F)	K9K 806	76	103	4	2	01.02.2008	-	D	8200395513
RENAULT	LAGUNA II (BT01)	1.5 dCi (BT0A)	K9K 780	81	110	4	2	01.10.2007	-	D	8200687905
RENAULT	MEGANE II (BM01_, CM01_)	1.5 dCi	K9K 724	63	86	4	2	01.05.2005	-	D	8200544135
RENAULT	MODUS (FJPO_)	1.5 dCi (JPOG, JPOH)	K9K 764	78	106	4	2	01.05.2005	-	D	
RENAULT	TWINGO (CN0_)	1.6 RS (CN0R)	K4M 754	98	133	4	4	01.05.2008	-	P	



Stock No: 5030

Brand	Model	Motorization	Engine	Kw	Hp	Cylinders	Valves	From Date	To Date	Fuel	OEM
RENAULT	ESPACE IV (JM01_)	1.9 dCi (JM0J, JM0G)	F9Q 680, F9Q 820	88	120	4	2	01.11.2002	-	D	8200523072
RENAULT	MEGANE II (BM01_, CM01_)	1.9 dCi (BM0G, CM0G)	F9Q 750	85	120	4	2	01.11.2002	-	D	8200268426
RENAULT	MEGANE II Estate (KM01_)	1.9 dCi	F9Q 800	85	120	4	2	01.08.2003	-	D	8200297996
RENAULT	MEGANE II Saloon (LM01_)	1.9 dCi (LM0G, LM1G, LM2C)	F9Q 800	85	120	4	2	01.09.2003	-	D	8200457775
RENAULT	SCÉNIC II (JM01_)	1.9 dCi (JM12, JM0G)	F9Q 812	85	120	4	2	01.06.2003	-	D	
RENAULT	MODUS (FJPO_)	1.5 dCi (JPOG, JPOH)	K9K 764	78	106	4	2	01.05.2005	-	D	
RENAULT	TWINGO (CN0_)	1.6 RS (CN0R)	K4M 754	98	133	4	4	01.05.2008	-	P	



Stock No: 2096

Brand	Model	Motorization	Engine	Kw	Hp	Cylinders	Valves	From Date	To Date	Fuel	OEM
RENAULT	MEGANE	20									8200366453
RENAULT	LAGUNA	20									



RENAULT - DACIA

Stock No: 2091

Brand	Model	Motorization	Engine	Kw	Hp	Cylinders	Valves	From Date	To Date	Fuel	OEM
RENAULT	CLIO II (BB01/2_, CB01/2_)	1.9 dTi (B/CB0U)	F9Q 760	59	80	4	2	01.12.1999	01.05.2005	D	8200689702
RENAULT	ESPACE III (JE0_)	1.9 dTi (JEDM)	F9Q 722	72	98	4	2	01.02.1999	01.10.2002	D	7700110329
RENAULT	KANGOO (KC01_)	1.9 dCi 4x4 (KCOV)	F9Q 782, F9Q 790	69	80	4	2	01.10.2001	/	D	7700113018
RENAULT	KANGOO (KC01_)	1.9 dTi (KCOU)	F9Q 760	59	80	4	2	01.02.2000	/	D	7700115309
RENAULT	LAGUNA I (B56_, 556_)	1.9 dCi (B56W)	F9Q 718	79	107	4	2	01.09.1999	01.03.2001	D	
RENAULT	LAGUNA I (B56_, 556_)	1.9 dTi (B55J)	F9Q 710, F9Q 716	72	98	4	2	01.10.1997	01.03.2001	D	
RENAULT	LAGUNA II (BG01_)	1.9 dCi (BGGG)	F9Q 750, F9Q 756	88	120	4	2	01.03.2001	/	D	
RENAULT	MEGANE I (BA01_)	1.9 dTi (BA0B, BA0N)	F9Q 730, F9Q 731	72	98	4	2	01.03.1997	01.02.2001	D	



Stock No: 2092

Brand	Model	Motorization	Engine	Kw	Hp	Cylinders	Valves	From Date	To Date	Fuel	OEM
DACIA	LOGAN (LS_)	1.5 dCi (LS0W)	K9K 796	65	86	4	2	01.09.2007	-	D	12303000AY
DACIA	LOGAN (LS_)	1.6 16V (LS0M)	K4M 690	77	105	4	4	01.02.2005	-	P	8200477936
NISSAN	ALMERA II (N16)	1.5 dCi	K9K 722	60	82	4	2	01.01.2003	-	D	
NISSAN	MICRA II (K12)	1.5 dCi	K9K 704	45	65	4	2	01.01.2003	-	D	
RENAULT	CLIO III (BR01, CR01)	1.5 dCi (BR17, CR17)	K9K 766	65	86	4	2	01.06.2005	-	D	
RENAULT	KANGOO (KW01_)	1.5 dCi (KW0A)	K9K 840	50	68	4	2	01.02.2008	-	D	
RENAULT	MEGANE II (BM01_, CM01_)	1.4 16V (BM0B, CM0B)	K4J 730	72	98	4	4	01.11.2002	-	P	
RENAULT	MEGANE II (BM01_, CM01_)	1.5 dCi	K9K 724	65	86	4	2	01.05.2005	-	D	
RENAULT	MODUS (FJPO_)	1.4 (JPO1, JPOJ)	K4J 770	72	98	4	4	01.12.2004	-	P	
RENAULT	MODUS (FJPO_)	1.5 dCi (FPOF, JPOF)	K9K 766	63	86	4	2	01.12.2004	-	D	
RENAULT	MODUS (FJPO_)	40685	K4M 792	65	86	4	4	01.12.2004	-	P	
RENAULT	MODUS (FJPO_)	1.6 (JPOB)	K4M 790	82	112	4	4	01.12.2004	-	P	
RENAULT	TWINGO (CN0_)	1.5 dCi (CN0E)	K9K 740	47	64	4	2	01.03.2007	-	D	



RENAULT - DACIA

AUDI - SEAT
SKODA - VOLKSWAGEN

Stock No: 5031

Stock No: 5033

Brand	Model	Motorization	Engine	Kw	Hp	Cylinders	Valves	From Date	To Date	Fuel	OEM
RENAULT	18 (154_)	2.1 D	852710,J86 711	49	67	4	2	1.11.1981	1.7.1986	D	7700853470
RENAULT	21 (848_)	2.1 D	J66 600,J66 740	53	72	4	2	1.9.1989	1.12.1992	D	7701349439 7700739486

Brand	Model	Motorization	Engine	Kw	Hp	Cylinders	Valves	From Date	To Date	Fuel	OEM
AUDI	A6 (4A, C4)	2.5 TDI	AEL	103	140	5	2	01.08.1994	01.10.1997	D	074105251AC
AUDI	A6 Avant (4A, C4)	2.5 TDI quattro	AEL	103	140	5	2	01.07.1995	01.12.1997	D	074105251N
VW	LT 28-35 II Bus (2DM)	2.5 SDI	AGX	55	75	5	2	01.07.1996	01.07.2006	D	074105251R
VW	LT 28-35 II Bus (2DM)	2.5 TDI	AHD	75	102	5	2	01.05.1996	01.08.1999	D	074105251T
VW	LT 28-35 II Bus (2DM)	2.5 TDI	ANJ	80	109	5	2	01.05.1999	01.07.2006	D	
VW	LT 28-35 II Bus (2DM)	2.5 TDI	APA	66	90	5	2	01.05.1999	01.07.2006	D	
VW	LT 28-35 II Bus (2DM)	2.5 TDI	BBE	61	83	5	2	01.05.2001	01.07.2006	D	
VW	LT 28-35 II Bus (2DM)	2.5 TDI	BBF	70	95	5	2	01.05.2001	01.07.2006	D	
VW	LT 28-46 II Box (2DX-0AE)	2.5 SDI	AGX	55	75	5	2	01.09.1996	01.07.2006	D	
VW	LT 28-46 II Box (2DX-0AE)	2.5 TDI	ANJ	80	109	5	2	01.05.1999	01.07.2006	D	
VW	LT 28-46 II Box (2DX-0AE)	2.5 TDI	APA	66	90	5	2	01.05.1999	01.07.2006	D	
VW	LT 28-46 II Box (2DX-0AE)	2.5 TDI	BBE	61	83	5	2	01.05.2001	01.07.2006	D	
VW	LT 28-46 II Box (2DX-0AE)	2.5 TDI	BBF	70	95	5	2	01.05.2001	01.07.2006	D	
VW	TRANSPORTER IV Box (70XA)	2.4 D	AJA	55	75	5	2	01.08.1997	01.04.2003	D	
VW	TRANSPORTER IV Bus (70XB, 70XC, 70B, 70W)	2.5 TDI	AHY	111	151	5	2	01.05.1998	01.04.2003	D	
VW	TRANSPORTER IV Bus (70XB, 70XC, 70B, 70W)	2.5 TDI	AJT	65	88	5	2	01.05.1998	01.04.2003	D	



Stock No: 5032

Brand	Model	Motorization	Engine	Kw	Hp	Cylinders	Valves	From Date	To Date	Fuel	OEM
RENAULT		1.9 D								D	



Stock No: 1055

Brand	Model	Motorization	Engine	Kw	Hp	Cylinders	Valves	From Date	To Date	Fuel	OEM
RENAULT	12										



AUDI - SEAT
SKODA - VOLKSWAGEN

Stock No: 5018

Brand	Model	Motorization	Engine	Kw	Hp	Cylinders	Valves	From Date	To Date	Fuel	OEM
AUDI	80 (8C, B4)	1.9 TD	AAZ	55	75	4	2	01.09.1991	01.12.1994	D	028105243G
AUDI	80 (8C, B4)	1.9 TDI	1Z	66	90	4	2	01.09.1991	01.12.1994	D	028105243H
SEAT	ALHAMBRA (7V8, 7V9)	1.9 TDI	1Z	66	90	4	2	01.04.1996	-	D	028105243K
SEAT	ALHAMBRA (7V8, 7V9)	1.9 TDI	AFN	81	110	4	2	01.08.1996	01.06.2000	D	028105243R
SEAT	CORDOBA (6K2/C2)	1.9 D	1Y	47	64	4	2	01.01.1996	01.06.1996	D	028105243T
SEAT	CORDOBA (6K2/C2)	1.9 SDI	AEY	47	64	4	2	01.08.1996	01.06.1999	D	
SEAT	CORDOBA (6K2/C2)	1.9 TD	AAZ	55	75	4	2	01.02.1993	01.08.1996	D	
SEAT	CORDOBA (6K2/C2)	1.9 TDI	1Z	66	90	4	2	01.08.1996	01.06.1999	D	
SEAT	CORDOBA (6K2/C2)	1.9 TDI	AFN	81	110	4	2	01.03.1997	01.06.1999	D	
SEAT	IBICA II (8K1)	1.9 D	1Y	47	64	4	2	01.04.1993	01.08.1996	D	
SEAT	IBICA II (8K1)	1.9 SDI	AEY	47	64	4	2	01.08.1996	01.08.1999	D	
SEAT	IBICA II (8K1)	1.9 TD	AAZ	55	75	4	2	01.03.1993	01.08.1996	D	
SEAT	IBICA II (8K1)	1.9 TDI	1Z	66	90	4	2	01.08.1996	01.08.1999	D	
SEAT	IBICA II (8K1)	1.9 TDI	AFN	81	110	4	2	01.02.1997	01.08.1999	D	
SEAT	INCA (8K9)	1.7 D	AHB	42	57	4	2	01.09.1996	01.06.2003	D	
SEAT	INCA (8K9)	1.9 D	1Y	47	64	4	2	01.11.1995	01.06.2003	D	
SEAT	TOLEDO I (1L)	1.9 D	1Y	47	64	4	2	01.12.1995	01.03.1999	D	
SEAT	TOLEDO I (1L)	1.9 D	1Y	50	68	4	2	01.05.1991	01.03.1999	D	
SEAT	TOLEDO I (1L)	1.9 TD	AAZ	55	75	4	2	01.05.1991	01.03.1999	D	
SEAT	TOLEDO I (1L)	1.9 TDI	1Z	66	90	4	2	01.08.1995	01.03.1999	D	
SEAT	TOLEDO I (1L)	1.9 TDI	AFN	81	110	4	2	01.11.1996	01.03.1999	D	
SKODA	FABIA (6V2)	1.9 SDI	ASY	47	64	4	2	01.12.1999	01.03.2008	D	
VW	CADDY II Box (9K9A)	1.9 D	1Y	47	64	4	2	01.11.1995	01.01.2004	D	
VW	CADDY II Box (9K9A)	1.9 SDI	AEY	47	64	4	2	01.11.1995	01.01.2004	D	
VW	CADDY II Box (9K9A)	1.9 TDI	1Z	66	90	4	2	01.09.1996	01.01.2004	D	
VW	GOLF III (1H1)	1.9 D	1Y	48	65	4	2	01.11.1991	01.08.1997	D	
VW	GOLF III (1H1)	1.9 SDI	AEY	47	64	4	2	01.07.1995	01.08.1997	D	
VW	GOLF III (1H1)	1.9 TD.GTD	AAZ	55	75	4	2	01.11.1991	01.08.1997	D	
VW	GOLF III (1H1)	1.9 TDI	1Z	66	90	4	2	01.09.1993	01.08.1997	D	
VW	GOLF III (1H1)	1.9 TDI	AFN	81	110	4	2	01.04.1996	01.08.1997	D	
VW	PASSAT (3A2, 35I)	1.9 TD	AAZ	55	75	4	2	01.03.1991	01.08.1996	D	
VW	PASSAT (3A2, 35I)	1.9 TDI	1Z	66	90	4	2	01.10.1993	01.08.1996	D	
VW	PASSAT (3A2, 35I)	1.9 TDI	AFN	81	110	4	2	01.03.1996	01.08.1996	D	
VW	POLO CLASSIC (6KV2)	110 1.9 TDI	AFN	81	110	4	2	01.06.1996	01.09.2001	D	
VW	POLO CLASSIC (6KV2)	57 1.7 SDI	AKW	42	57	4	2	01.07.1997	01.09.2001	D	
VW	POLO CLASSIC (6KV2)	64 1.9 SDI	1Y	47	64	4	2	01.12.1995	01.08.1999	D	
VW	SHARAN (7M5, 7M9, 7M6)	1.9 TDI	1Z	66	90	4	2	01.09.1995	-	D	
VW	SHARAN (7M5, 7M9, 7M6)	1.9 TDI	AFN	81	110	4	2	01.09.1996	01.04.2000	D	
VW	TRANSPORTER IV Box (70XA)	1.9 D	1X	45	61	4	2	01.07.1990	01.04.2003	D	
VW	TRANSPORTER IV Box (70XA)	1.9 TD	ABL	50	68	4	2	01.10.1992	01.04.2003	D	
VW	VENTO (1H2)	1.9 D	1Y	48	65	4	2	01.11.1991	01.09.1998	D	
VW	VENTO (1H2)	1.9 TD	AAZ	55	75	4	2	01.11.1991	01.09.1998	D	
VW	VENTO (1H2)	1.9 TDI	1Z	66	90	4	2	01.09.1993	01.09.1998	D	
VW	VENTO (1H2)	1.9 TDI	AFN	81	110	4	2	01.04.1996	01.09.1998	D	



AUDI - SEAT
SKODA - VOLKSWAGEN

Stock No: 5034

Brand	Model	Motorization	Engine	Kw	Hp	Cylinders	Valves	From Date	To Date	Fuel	OEM
AUDI	A3 (8L1)	1.9 TDI	ASZ	96	130	4	2	01.08.2000	-	D	038105243K
AUDI	A3 (8L1)	1.9 TDI	ATD	74	100	4	2	01.10.2000	-	D	
SEAT	ALHAMBRA (7V8, 7V9)	1.9 TDI	1Z	66	90	4	2	01.04.1996	-	D	
SEAT	ALHAMBRA (7V8, 7V9)	1.9 TDI	ASZ	96	131	4	2	01.11.2002	-	D	
SEAT	ALHAMBRA (7V8, 7V9)	1.9 TDI	AUY	85	115	4	2	01.06.2000	-	D	
SEAT	LEON (1M1)	1.9 TDI	ASZ	96	130	4	2	01.05.2003	01.06.2006	D	
SEAT	LEON (1M1)	1.9 TDI Syncro	ARL	110	150	4	2	01.05.2002	01.06.2006	D	
SEAT	TOLEDO II (1M2)	1.9 TDI	ARL	110	150	4	2	01.10.2000	01.05.2005	D	
SEAT	TOLEDO II (1M2)	1.9 TDI	ASZ	96	130	4	2	01.05.2003	01.05.2006	D	
SKODA	OCTAVIA (1U2)	1.9 TDI	ASZ	96	130	4	2	01.01.2003	-	D	
SKODA	OCTAVIA Combi (1U5)	1.9 TDI	ASZ	96	130	4	2	01.01.2003	-	D	
SKODA	OCTAVIA Combi (1U5)	1.9 TDI 4x4	ATD	74	100	4	2	01.09.2000	-	D	
VW	BORA (1J2)	1.9 TDI	AJM	85	115	4	2	01.12.1998	01.05.2001	D	
VW	BORA (1J2)	1.9 TDI	ARL	110	150	4	2	01.05.2000	01.05.2005	D	
VW	BORA (1J2)	1.9 TDI	ASZ	96	130	4	2	01.11.2000	01.05.2005	D	
VW	BORA (1J2)	1.9 TDI	ATD	74	101	4	2	01.09.2000	01.05.2005	D	
VW	GOLF IV (1J1)	1.9 TDI	AJM	85	115	4	2	01.12.1998	01.05.2001	D	
VW	GOLF IV (1J1)	1.9 TDI	ASZ	96	130	4	2	01.11.2000	01.05.2005	D	
VW	GOLF IV (1J1)	1.9 TDI	ATD	74	101	4	2	01.09.2000	01.05.2005	D	
VW	MULTIVAN V (7HM, 7HN, 7HF, 7EM, 7EN)	1.9 TDI	AXB	77	105	4	2	01.04.2003	-	D	
VW	NEW BEETLE (9C1, 1C1)	1.9 TDI	ATD	74	101	4	2	01.02.2001	-	D	
VW	SHARAN (7M5, 7M9, 7M5)	1.9 TDI	1Z	66	90	4	2	01.09.1995	-	D	
VW	SHARAN (7M5, 7M9, 7M5)	1.9 TDI	ASZ	96	130	4	2	01.11.2002	-	D	
VW	SHARAN (7M5, 7M9, 7M5)	1.9 TDI	AUY	85	115	4	2	01.04.2000	-	D	
VW	TRANSPORTER V Box (7HA, 7HH, 7EA, 7EH)	1.9 TDI	AXB	77	105	4	2	01.04.2003	-	D	
VW	TRANSPORTER V Box (7HA, 7HH, 7EA, 7EH)	1.9 TDI	AXC	63	85	4	2	01.04.2003	-	D	



AUDI - SEAT
SKODA - VOLKSWAGEN

Stock No: 5035

Brand	Model	Motorization	Engine	Kw	Hp	Cylinders	Valves	From Date	To Date	Fuel	OEM
AUDI	A4 (80C, B5)	1.9 TDI	1Z	66	90	4	2	01.01.1995	01.11.2000	D	0281052430
AUDI	A4 (80C, B5)	1.9 TDI	APF	55	75	4	2	01.12.1995	01.11.2000	D	
AUDI	A4 (80C, B5)	1.9 TDI	AFN	81	110	4	2	01.10.1995	01.11.2000	D	
AUDI	A4 (80C, B5)	1.9 TDI quattro	AFN	81	110	4	2	01.09.1996	01.11.2000	D	
AUDI	A4 Avant (80S, B5)	1.9 TDI	1Z	66	90	4	2	01.02.1996	01.09.2001	D	
AUDI	A4 Avant (80S, B5)	1.9 TDI	APF	55	75	4	2	01.03.1996	01.09.2001	D	
AUDI	A4 Avant (80S, B5)	1.9 TDI	AFN	81	110	4	2	01.02.1996	01.09.2001	D	
AUDI	A4 Avant (80S, B5)	1.9 TDI quattro	AFN	81	110	4	2	01.09.1996	01.09.2001	D	
AUDI	A6 (4B, C5)	1.9 TDI	AFN	81	110	4	2	01.04.1997	01.10.2000	D	
AUDI	A6 Avant (4B, C5)	1.9 TDI	AFN	81	110	4	2	01.02.1998	01.04.2001	D	
VW	PASSAT (3B2)	1.9 TDI	AFN	81	110	4	2	01.10.1996	01.11.2000	D	
VW	PASSAT (3B2)	1.9 TDI	AHH	66	90	4	2	01.10.1996	01.11.2000	D	
VW	PASSAT (3B2)	1.9 TDI Syncro 4motion	AFN	81	110	4	2	01.10.1996	01.11.2000	D	
VW	PASSAT Variant (3B5)	1.9 TDI	AFN	81	110	4	2	01.06.1997	01.11.2000	D	
VW	PASSAT Variant (3B5)	1.9 TDI	AHH	66	90	4	2	01.06.1997	01.11.2000	D	
VW	PASSAT Variant (3B5)	1.9 TDI Syncro 4motion	AFN	81	110	4	2	01.06.1997	01.11.2000	D	



Stock No: 5036

Brand	Model	Motorization	Engine	Kw	Hp	Cylinders	Valves	From Date	To Date	Fuel	OEM
AUDI	A4 (80C, B5)	1.9 TDI	AJM	85	116	4	2	01.03.2000	01.11.2000	D	038105243F
AUDI	A4 (80C, B5)	1.9 TDI quattro	AJM	85	116	4	2	01.03.2000	01.11.2000	D	
AUDI	A4 (8E2, B6)	1.9 TDI	AVB	74	101	4	2	01.06.2001	01.12.2004	D	
AUDI	A4 (8E2, B6)	1.9 TDI	AVF	96	130	4	2	01.11.2000	01.12.2004	D	
AUDI	A4 (8E2, B6)	1.9 TDI quattro	AVF	96	130	4	2	01.11.2001	01.12.2004	D	
AUDI	A4 (8EC)	1.9 TDI	BKE	85	116	4	2	01.11.2004	/	D	
AUDI	A4 Avant (80S, B5)	1.9 TDI	AJM	85	115	4	2	01.03.2000	01.09.2001	D	
AUDI	A4 Avant (80S, B5)	1.9 TDI quattro	AJM	85	115	4	2	01.03.2000	01.09.2001	D	
AUDI	A4 Avant (8E5, B6)	1.9 TDI	AVB	74	101	4	2	01.11.2001	01.12.2004	D	
AUDI	A4 Avant (8E5, B6)	1.9 TDI quattro	AVF	96	130	4	2	01.11.2001	01.12.2004	D	
AUDI	A6 (4B, C5)	1.9 TDI	AJM	85	115	4	2	01.07.2000	01.01.2005	D	
AUDI	A6 (4B, C5)	1.9 TDI	AVF	96	130	4	2	01.08.2001	01.01.2005	D	
SKODA	SUPERB (3U4)	1.9 TDI	AVF	96	130	4	2	01.02.2002	01.03.2008	D	
VW	PASSAT (3B3)	1.9 TDI	AVB	74	101	4	2	01.11.2000	01.05.2005	D	
VW	PASSAT (3B3)	1.9 TDI	AVF	96	130	4	2	01.11.2000	01.05.2005	D	
VW	PASSAT Variant (3B6)	1.9 TDI	AVB	74	101	4	2	01.11.2000	01.05.2005	D	
VW	PASSAT Variant (3B6)	1.9 TDI	AVF	96	130	4	2	01.11.2000	01.05.2005	D	



AUDI - SEAT
SKODA - VOLKSWAGEN

Stock No: 5037

Brand	Model	Motorization	Engine	Kw	Hp	Cylinders	Valves	From Date	To Date	Fuel	OEM
SEAT	AROSA (5H)	1.7 SDI	AKU	44	60	4	2	01.08.1997	01.05.2004	D	028105243AC
SKODA	FELICIA I (6U1)	1.9 D	AEF	47	64	4	2	01.10.1995	01.03.1998	D	
SKODA	FELICIA I Estate (6U5)	1.9 D	AEF	47	64	4	2	01.10.1995	01.03.1998	D	
SKODA	FELICIA II (6U1)	1.9 D	AEF	47	64	4	2	01.01.1998	01.05.2001	D	
SKODA	FELICIA II Estate (6U5)	1.9 D	AEF	47	64	4	2	01.01.1998	01.05.2001	D	
VW	CADDY II Pickup (9U7)	1.9 D	AEF	47	64	4	2	01.05.1996	01.12.2000	D	
VW	LUPLO (5X1, 5E1)	1.7 SDI	AKU	44	60	4	2	01.09.1996	01.07.2005	D	
VW	POLO (8N1)	60 1.7 SDI	AKU	44	60	4	2	01.03.1997	01.10.1999	D	
VW	POLO (8N1)	64 1.9 D	AEF	47	64	4	2	01.10.1994	01.10.1999	D	
VW	POLO (8N1)	64 1.9 SDI	AGD	47	64	4	2	01.07.1996	01.10.1999	D	



Stock No: 5038

Brand	Model	Motorization	Engine	Kw	Hp	Cylinders	Valves	From Date	To Date	Fuel	OEM
AUDI	A2 (82D)	1.4 TDI	AMP-SHC-ATL	55	75	3		01.02.2000	01.09.2005	D	045105243C
SEAT	AROSA (5H)	1.4 TDI	AMF	55	75	3		01.05.1997	01.05.2001	D	
SEAT	CORDOBA (6L2)	1.4 TDI	BNM-AMF-BNV-BNS	51	70	3		01.09.2002	-	D	
SEAT	IBIZA IV (5L1)	1.4 TDI	BNM-AMF-BNV-BNS	59	80	3		01.02.2002	-	D	
SKODA	FABIA (5Y2)	1.4 TDI	BNM-AMF-BNV	51	70	3		01.08.1999	01.03.2008	D	
SKODA	FABIA (5Y3)	1.4 TDI	BNM-AMF-BNV	59	80	3		01.10.1999	01.12.2007	D	
SKODA	FABIA Combi (5Y5)	1.4 TDI	BNM-AMF-BNV	55	75	3		01.04.2000	01.12.2007	D	
SKODA	ROOMSTER (5J)	1.4 TDI	BNM-BNV-BNS	59	80			01.05.2006	-	D	



AUDI - SEAT
SKODA - VOLKSWAGEN

Stock No: 5015

Brand	Model	Motorization	Engine	Kw	Hp	Cylinders	Valves	From Date	To Date	Fuel	OEM
AUDI	A3 (8L1)	1.9 TDI	AGR	66	90	4	2	01.09.1996	01.07.2001	D	03G105243
AUDI	A3 (8L1)	1.9 TDI	AHF	81	110	4	2	01.08.1997	01.07.2001	D	
AUDI	A3 (8P1)	1.9 TDI	BKC	77	105	4	2	01.05.2003	-	D	
AUDI	A3 (8P1)	2.0 TDI	AZV	100	135	4	4	01.05.2003	-	D	
AUDI	A3 (8P1)	2.0 TDI 16V	BKD	103	140	4	4	01.05.2003	-	D	
AUDI	A3 (8P1)	2.0 TDI 16V quattro	BKD	103	140	4	4	01.08.2004	-	D	
AUDI	A4 (8E2, 8E)	1.9 TDI	AVB	74	101	4	2	01.05.2001	01.12.2004	D	
AUDI	A4 (8E2, 8E)	1.9 TDI	AVF	96	130	4	2	01.11.2000	01.12.2004	D	
AUDI	A4 (8E2, 8E)	1.9 TDI	BKE	85	115	4	2	01.06.2004	01.12.2004	D	
AUDI	A4 (8E2, 8E)	1.9 TDI quattro	AVF	96	130	4	2	01.11.2000	01.12.2004	D	
AUDI	A4 (8EC)	1.9 TDI	BKE	85	115	4	2	01.11.2004	-	D	
AUDI	A4 (8EC)	2.0 TDI	BNA	100	135	4	4	01.11.2004	-	D	
AUDI	A4 (8EC)	2.0 TDI 16V	BLB	103	140	4	4	01.11.2004	-	D	
AUDI	A4 Avant (8E5, 8E)	1.9 TDI	AVB	74	101	4	2	01.11.2000	01.12.2004	D	
AUDI	A4 Avant (8E5, 8E)	1.9 TDI	AVF	96	130	4	2	01.09.2001	01.12.2004	D	
AUDI	A4 Avant (8E5, 8E)	1.9 TDI	BKE	85	115	4	2	01.06.2004	01.12.2004	D	
AUDI	A4 Avant (8ED)	1.9 TDI	BKE	85	115	4	2	01.11.2004	-	D	
AUDI	A4 Avant (8ED)	2.0 TDI	BNA	100	135	4	4	01.11.2004	-	D	
AUDI	A4 Avant (8ED)	2.0 TDI 16V	BLB	103	140	4	4	01.11.2004	-	D	
AUDI	A4 Avant (8ED)	2.0 TDI quattro	BPW	103	140	4	2	01.01.2006	-	D	
AUDI	A6 (4F2)	2.0 TDI	BLB	103	140	4	4	01.07.2004	01.10.2008	D	
AUDI	A6 Avant (4F5)	2.0 TDI	BLB	103	140	4	4	01.06.2005	01.10.2008	D	
SEAT	ALTEA (5P1)	1.9 TDI	BJS	77	105	4	2	01.04.2004	-	D	
SEAT	ALTEA (5P1)	2.0 TDI	AZV	100	135	4	4	01.03.2004	01.05.2009	D	
SEAT	ALTEA (5P1)	2.0 TDI 16V	BKD	103	140	4	4	01.03.2004	-	D	
SEAT	CORDOBA (5L2)	1.9 TDI	ASZ	96	130	4	2	01.10.2002	-	D	
SEAT	CORDOBA (5L2)	1.9 TDI	ATD	74	100	4	2	01.09.2002	-	D	
SEAT	INCA (6K9)	1.9 SDI	AEY	47	64	4	2	01.11.1995	01.06.2003	D	
SEAT	INCA (6K9)	1.9 TDI	ALH	66	90	4	2	01.09.1996	01.08.2003	D	
SEAT	LEON (1M1)	1.9 SDI	AGM	50	68	4	2	01.11.1999	01.06.2006	D	
SEAT	LEON (1M1)	1.9 TDI	AGR	66	90	4	2	01.11.1999	01.06.2006	D	
SEAT	LEON (1M1)	1.9 TDI	AHF	81	110	4	2	01.11.1999	01.06.2006	D	
SEAT	LEON (1M1)	1.9 TDI	ASZ	96	130	4	2	01.05.2003	01.06.2006	D	
SEAT	LEON (1P1)	1.9 TDI	BKC	77	105	4	2	01.07.2005	-	D	
SEAT	LEON (1P1)	2.0 TDI 16V	BKD	103	140	4	4	01.07.2005	-	D	
SEAT	TOLEDO II (1M2)	1.9 TDI	AGR	66	90	4	2	01.04.1999	01.05.2006	D	
SEAT	TOLEDO II (1M2)	1.9 TDI	AHF	81	110	4	2	01.04.1999	01.05.2006	D	
SEAT	TOLEDO II (1M2)	1.9 TDI	ASZ	96	130	4	2	01.05.2003	01.05.2006	D	
SEAT	TOLEDO III (5P2)	1.9 TDI	BJS	77	105	4	2	01.10.2004	-	D	
SEAT	TOLEDO III (5P2)	2.0 TDI 16V	BKD	103	140	4	4	01.04.2004	01.05.2009	D	

Stock No: 5015

AUDI - SEAT
SKODA - VOLKSWAGEN

Brand	Model	Motorization	Engine	Kw	Hp	Cylinders	Valves	From Date	To Date	Fuel	OEM
SKODA	FABIA (6V2)	1.9 TDI	ATO	74	100	4	2	01.01.2000	01.03.2008	D	
SKODA	OCTAVIA (1U2)	1.9 SDI	AGP	50	68	4	2	01.06.1997	-	D	
SKODA	OCTAVIA (1U2)	1.9 TDI	AGR	66	90	4	2	01.06.1996	-	D	
SKODA	OCTAVIA (1U2)	1.9 TDI	AHF	81	110	4	2	01.06.1997	-	D	
SKODA	OCTAVIA (123)	1.9 TDI	BJS	77	105	4	2	01.06.2004	-	D	
SKODA	OCTAVIA (123)	2.0 TDI 16V	BKD	103	140	4	4	01.02.2004	-	D	
SKODA	OCTAVIA Combi (1U5)	1.9 SDI	AGP	50	68	4	2	01.07.1998	-	D	
SKODA	OCTAVIA Combi (1U5)	1.9 TDI	AGR	66	90	4	2	01.07.1998	-	D	
SKODA	OCTAVIA Combi (1U5)	1.9 TDI	AHF	81	110	4	2	01.07.1998	-	D	
SKODA	OCTAVIA Combi (125)	1.9 TDI	BJS	77	105	4	2	01.09.2004	-	D	
SKODA	OCTAVIA Combi (125)	2.0 TDI	BMM	103	140	4	2	01.11.2005	-	D	
SKODA	OCTAVIA Combi (115)	2.0 TDI 16V	BKD	103	140	4	4	01.02.2004	-	D	
VW	BORA (1J2)	1.9 SDI	AGP	50	68	4	2	01.10.1998	01.08.2005	D	
VW	BORA (1J2)	1.9 TDI	AGR	66	90	4	2	01.10.1998	01.06.2001	D	
VW	BORA (1J2)	1.9 TDI	AHF	81	110	4	2	01.10.1998	01.06.2001	D	
VW	GOLF IV (1J1)	1.9 SDI	AGP	50	68	4	2	01.06.1997	01.06.2005	D	
VW	GOLF IV (1J1)	1.9 TDI	AGR	66	90	4	2	01.10.1997	01.05.2004	D	
VW	GOLF IV (1J1)	1.9 TDI	AHF	81	110	4	2	01.06.1997	01.05.2004	D	
VW	GOLF IV (1J1)	1.9 TDI	ASZ	96	130	4	2	01.11.2000	01.06.2008	D	
VW	GOLF IV (1J1)	1.9 TDI	ATO	74	101	4	2	01.06.2000	01.06.2005	D	
VW	GOLF PLUS (5M1, 521)	1.9 TDI	BKC	77	105	4	2	01.01.2005	-	D	
VW	GOLF PLUS (5M1, 521)	1.9 TDI	BRU	66	90	4	2	01.05.2005	-	D	
VW	GOLF PLUS (5M1, 521)	2.0 TDI	BMM	103	140	4	2	01.12.2005	-	D	
VW	GOLF V (1K1)	1.9 TDI	BKC	77	105	4	2	01.10.2003	-	D	
VW	GOLF V (1K1)	1.9 TDI	BRU	66	90	4	2	01.05.2004	-	D	
VW	GOLF V (1K1)	2.0 SDI	BDK	55	75	4	2	01.01.2004	-	D	
VW	GOLF V (1K1)	2.0 TDI	BMM	125	170	4	4	01.11.2005	-	D	
VW	GOLF V (1K1)	2.0 TDI 16V	BKD	103	140	4	4	01.10.2003	-	D	
VW	JETTA III (1K2)	1.9 TDI	BKC	77	105	4	2	01.08.2005	-	D	
VW	JETTA III (1K2)	2.0 TDI	BMM	103	140	4	2	01.10.2005	-	D	
VW	NEW BEETLE (9C1, 1C1)	1.9 TDI	ALH	66	90	4	2	01.01.1998	01.06.2004	D	
VW	PASSAT (3C2)	1.9 TDI	BKC	77	105	4	2	01.03.2005	-	D	
VW	PASSAT (3C2)	2.0 TDI	BMP	103	140	4	2	01.03.2005	-	D	
VW	PASSAT (3C2)	2.0 TDI	BMR	125	170	4	4	01.06.2005	-	D	
VW	PASSAT Variant (3C5)	1.9 TDI	BKC	77	105	4	2	01.06.2005	-	D	
VW	PASSAT Variant (3C5)	2.0 TDI	BMR	125	170	4	4	01.06.2005	-	D	
VW	PASSAT Variant (3C5)	2.0 TDI 16V	BKP	103	140	4	4	01.06.2005	-	D	
VW	PASSAT Variant (3C5)	2.0 TDI 16V 4motion	BKP	103	140	4	4	01.06.2005	-	D	
VW	SHARAN (7M8, 7M9, 7M6)	1.9 TDI	1Z	66	90	4	2	01.09.1995	-	D	
VW	SHARAN (7M8, 7M9, 7M6)	1.9 TDI	ASZ	96	130	4	2	01.11.2002	-	D	
VW	SHARAN (7M8, 7M9, 7M6)	1.9 TDI	AUY	85	115	4	2	01.04.2000	-	D	
VW	SHARAN (7M8, 7M9, 7M6)	1.9 TDI	STB	110	150	4	2	01.06.2005	-	D	
VW	TOURAN (1T1, 1T2, 1T3)	1.9 TDI	AVQ	74	100	4	2	01.02.2003	-	D	
VW	TOURAN (1T1, 1T2, 1T3)	1.9 TDI	BKC	77	105	4	2	01.08.2003	-	D	
VW	TOURAN (1T1, 1T2, 1T3)	1.9 TDI	BRU	66	90	4	2	01.11.2004	-	D	
VW	TOURAN (1T1, 1T2, 1T3)	2.0 TDI	AZV	100	135	4	4	01.02.2003	-	D	
VW	TOURAN (1T1, 1T2, 1T3)	2.0 TDI 16V	BKD	103	140	4	4	01.08.2003	-	D	
VW	TRANSPORTER V Bus (7H6, 7HJ, 7E8, 7EJ)	1.9 TDI	AXB	77	105	4	2	01.04.2003	-	D	
VW	TRANSPORTER V Bus (7H6, 7HJ, 7E8, 7EJ)	1.9 TDI	AXC	63	85	4	2	01.04.2003	-	D	



VOLVO - AUDI
VOLKSWAGEN

Stock No: 5033

Brand	Model	Motorization	Engine	Kw	Hp	Cylinders	Valves	From Date	To Date	Fuel	OEM
AUDI	A6 (4A, C4)	2.5 TDI	AEL	103	140	5	2	01.08.1994	01.10.1997	D	074106251AC
AUDI	A6 Avant (4A, C4)	2.5 TDI quattro	AEL	103	140	5	2	01.07.1995	01.12.1997	D	074106251N
VW	LT 28-35 II Bus (2DM)	2.5 SDI	AGX	55	75	5	2	01.07.1996	01.07.2006	D	074106251R
VW	LT 28-35 II Bus (2DM)	2.5 TDI	AHD	75	102	5	2	01.05.1996	01.06.1999	D	074106251T
VW	LT 28-35 II Bus (2DM)	2.5 TDI	ANJ	80	109	5	2	01.05.1999	01.07.2005	D	
VW	LT 28-35 II Bus (2DM)	2.5 TDI	APA	66	90	5	2	01.05.1999	01.07.2005	D	
VW	LT 28-35 II Bus (2DM)	2.5 TDI	BBE	61	83	5	2	01.05.2001	01.07.2005	D	
VW	LT 28-35 II Bus (2DM)	2.5 TDI	BBF	70	95	5	2	01.05.2001	01.07.2005	D	
VW	LT 28-46 II Box (2DX0AE)	2.5 SDI	AGX	55	75	5	2	01.09.1996	01.07.2005	D	
VW	LT 28-46 II Box (2DX0AE)	2.5 TDI	ANJ	80	109	5	2	01.05.1999	01.07.2005	D	
VW	LT 28-46 II Box (2DX0AE)	2.5 TDI	APA	66	90	5	2	01.05.1999	01.07.2005	D	
VW	LT 28-46 II Box (2DX0AE)	2.5 TDI	BBE	61	83	5	2	01.05.2001	01.07.2005	D	
VW	LT 28-46 II Box (2DX0AE)	2.5 TDI	BBF	70	95	5	2	01.05.2001	01.07.2005	D	
VW	TRANSPORTER IV Box (70XA)	2.4 D	AJA	55	75	5	2	01.08.1997	01.04.2003	D	
VW	TRANSPORTER IV Bus (70XB, 70XC, 70D, 70W)	2.5 TDI	AHY	111	151	5	2	01.05.1998	01.04.2003	D	
VW	TRANSPORTER IV Bus (70XB, 70XC, 70D, 70W)	2.5 TDI	AJT	65	88	5	2	01.05.1998	01.04.2003	D	



Stock No: 5039

Brand	Model	Motorization	Engine	Kw	Hp	Cylinders	Valves	From Date	To Date	Fuel	OEM
VOLVO	850 (LS)	20	B 5202 S	93	126	5	2	01.08.1994	01.12.1996	F	1275801
VOLVO	850 (LS)	20	B 5204 F	105	143	5	2	01.06.1991	01.12.1996	F	
VOLVO	850 (LS)	2.3 T5	B 5234 FT	166	226	5	4	01.08.1993	01.07.1996	F	
VOLVO	850 (LS)	2.3 T5-R	B 5234 T4	184	250	5	4	01.08.1995	01.12.1996	F	
VOLVO	850 (LS)		B 5252	103	140	5	2	01.06.1991	01.07.1994	F	
VOLVO	850 (LS)	2.5	B 5252 S	105	144	5	2	01.08.1994	01.12.1996	F	
VOLVO	850 (LS)	25	B 5254 S	125	170	5	4	01.08.1991	01.12.1996	F	
VOLVO	850 Estate (LW)	2.5 AWD	B 5254 T	142	193	5	4	01.04.1996	01.12.1996	F	
VOLVO	C70 I Coupe	2.3 T-5	B 5234 T3	176	240	5	4	01.03.1997	01.09.2002	F	
VOLVO	S70 (F80_)	20	B 5202 S	93	126	5	2	01.01.1997	01.11.2000	F	
VOLVO	S70 (F80_)	2.3 T-5	B 5234 T3	176	239	5	4	01.01.1997	01.11.2000	F	
VOLVO	S70 (F80_)	24	B 5244 S2	103	140	5	4	01.08.1999	01.11.2000	F	
VOLVO	S70 (F80_)	25	B 5252 S	105	144	5	2	01.01.1997	01.11.2000	F	
VOLVO	V70 I Estate (F80_)	20	B 5202 S	93	126	5	2	01.01.1997	01.03.2000	F	
VOLVO	V70 I Estate (F80_)	2.3 T-5	B 5234 T3	176	239	5	4	01.01.1997	01.03.2000	F	
VOLVO	V70 I Estate (F80_)	24	B 5244 S2	103	140	5	4	01.08.1999	01.05.2000	F	
VOLVO	V70 I Estate (F80_)	25	B 5252 S	105	144	5	2	01.01.1997	01.03.2000	F	

Stock No: 3027

Brand	Model	Motorization	Engine	Kw	Hp	Cylinders	Valves	From Date	To Date	Fuel	OEM
VOLVO	S40 II (MS)	1.6 D	D 4164 T	81	110	4	4	01.01.2005	-	D	31251290
VOLVO	V50 (MW)	1.6 D	D 4164 T	81	110	4	4	01.01.2005	-	D	



Stock No: 3013

Brand	Model	Motorization	Engine	Kw	Hp	Cylinders	Valves	From Date	To Date	Fuel	OEM
VOLVO	C30	16	B 4154 S3	74	100	4		01.10.2006	-	D	30788499
VOLVO	S40 II (MS)	16	B 4154 S3	74	101	4		01.01.2004	-	D	
VOLVO	V50 (MW)	16	B 4154 S3	74	101	4		01.04.2004	-	D	



Stock No: 5014

Brand	Model	Motorization	Engine	Kw	Hp	Cylinders	Valves	From Date	To Date	Fuel	OEM
VOLVO	C30	2.0 D	D 4204 T	100	136	4		01.10.2006	-	D	30725177
VOLVO	S40 II (MS)	2.0 D	D 4204 T	100	136	4		01.01.2004	-	D	30725259
VOLVO	V50 (MW)	2.0 D	D 4204 T	100	136	4		01.04.2004	-	D	
VOLVO	C70 II Cabriolet	2.0 D	D 4204 T	100	136	4		01.03.2006	-	D	
VOLVO	V70 III Kombi	2.0 D	D 4204 T	100	136	4		01.08.2007	-	D	
VOLVO	S80 II	-	-	-	-	-	-	01.03.2006	-	D	



ISUZU

ISUZU

Stock No: 5040

Stock No: 5043

Brand	Model	Motorization	Engine	Kw	Hp	Cylinders	Valves	From Date	To Date	Fuel	OEM
ISUZU	NPR59										897136180

Brand	Model	Motorization	Engine	Kw	Hp	Cylinders	Valves	From Date	To Date	Fuel	OEM
ISUZU	NKR 55 ŞAMPİYON										8972299000



Stock No: 5041

Stock No: 5044

Brand	Model	Motorization	Engine	Kw	Hp	Cylinders	Valves	From Date	To Date	Fuel	OEM
ISUZU	NPR59										8941393422

Brand	Model	Motorization	Engine	Kw	Hp	Cylinders	Valves	From Date	To Date	Fuel	OEM
ISUZU	VFR										8941229604



Stock No: 5042

Stock No: 5045

Brand	Model	Motorization	Engine	Kw	Hp	Cylinders	Valves	From Date	To Date	Fuel	OEM
ISUZU	NKR 55 ŞAMPİYON										8972299000

Brand	Model	Motorization	Engine	Kw	Hp	Cylinders	Valves	From Date	To Date	Fuel	OEM
ISUZU	ŞAMPİYON NPR 66										8971320142
ISUZU	NQR 70										8972220311



mitsubishi

mitsubishi

Stock No: 5046

Stock No: 5049

Brand	Model	Motorization	Engine	Kw	Hp	Cylinders	Valves	From Date	To Date	Fuel	OEM
mitsubishi	DELICA Bus	2.5 TD 4WD						198.811	-	D	MD-110165
mitsubishi	PAJERO/SHOGUN II	2.5 TD 4x4						199.012	200.004	D	23129-42070
mitsubishi	STRADA	2.5 D						199.606	-	D	
mitsubishi	STRADA	2.5 TD 4x4						199.606	-	D	
mitsubishi	L 300 Flatbed	2.5 D						199.411	-	D	

Brand	Model	Motorization	Engine	Kw	Hp	Cylinders	Valves	From Date	To Date	Fuel	OEM
mitsubishi											ME-012356



Stock No: 5047

Stock No: 5050

Brand	Model	Motorization	Engine	Kw	Hp	Cylinders	Valves	From Date	To Date	Fuel	OEM
mitsubishi	DELICA Bus	2.5 TD 4WD	P26V, P26V	64	87	4		198.811	-	D	MD-110165
mitsubishi	PAJERO/SHOGUN II	2.5 TD 4x4	V24C, V24W	73	99	4		199.012	200.004	D	
mitsubishi	STRADA	2.5 D	K64T	55	76	4		199.606	-	D	
mitsubishi	STRADA	2.5 TD 4x4	K74T	73	99	4		199.606	-	D	
mitsubishi	L 300 Flatbed	2.5 D	P15T	64	87	4		199.411	-	D	

Brand	Model	Motorization	Engine	Kw	Hp	Cylinders	Valves	From Date	To Date	Fuel	OEM
mitsubishi	659 FE-515										ME-215081



Stock No: 5048

Stock No: 5051

Brand	Model	Motorization	Engine	Kw	Hp	Cylinders	Valves	From Date	To Date	Fuel	OEM
mitsubishi	PAJERO/SHOGUN I	2.5 TD						198.911	199.011	D	MD-374223
mitsubishi	Pajero/Shogun I Open Off-Road Vehicle	2.5 TD						198.911	199.011	D	
mitsubishi	Pajero/Shogun I Open Off-Road Vehicle	2.5 TD						199.012	200.004	D	
mitsubishi	PAJERO/SHOGUN II	2.5 TD 4x4						199.012	200.004	D	
mitsubishi	TRITON Pickup	2.5 TD 4WD						199.211	199.606	D	
mitsubishi	STRADA	2.5 D						199.606	-	D	
mitsubishi	STRADA	2.5 TD 4WD						200.109	-	D	
mitsubishi	G-WAGON	2.5 TD						199.811	-	D	
mitsubishi	G-WAGON	2.5 TD						200.207	-	D	
mitsubishi	G-WAGON	2.5 TD						200.308	-	D	

Brand	Model	Motorization	Engine	Kw	Hp	Cylinders	Valves	From Date	To Date	Fuel	OEM
mitsubishi	LANCER							2004	2006		MD-356151



Stock No: 5052

Brand	Model	Motorization	Engine	Kw	Hp	Cylinders	Valves	From Date	To Date	Fuel	OEM
mitsubishi	CARISMA							2004	2006		4413748
											4414115
											93161258
											931170225



HYUNDAI - KIA
NISSAN

Stock No: 5053

Brand	Model	Motorization	Engine	Kw	Hp	Cylinders	Valves	From Date	To Date	Fuel	OEM
HYUNDAI	EXCEL (X-3)	1.3		44	60	4		199.410	200.001	F	23124-22700
HYUNDAI	EXCEL (X-3)	1.3		55	75	4		199.410	200.001	F	
HYUNDAI	EXCEL (X-3)	1.3 i 12V		62	84	4		199.410	200.001	F	
HYUNDAI	EXCEL (X-3)	1.5 i 12V		65	88	4		199.410	200.001	F	
HYUNDAI	EXCEL (X-3)	1.5 i 18V		73	99	4		199.512	200.001	F	
HYUNDAI	EXCEL (X-3)	1.3		40	54	4		199.509	199.805	F	
HYUNDAI	PONY Saloon (X-3)	1.3		44	60	4		199.410	200.001	F	
HYUNDAI	PONY Saloon (X-3)	1.3		55	75	4		199.410	200.001	F	
HYUNDAI	PONY Saloon (X-3)	1.3 i 12V		62	84	4		199.410	200.001	F	
HYUNDAI	PONY Saloon (X-3)	1.5 i 12V		65	88	4		199.410	200.001	F	
HYUNDAI	PONY Saloon (X-3)	1.5 i 18V		73	99	4		199.510	200.001	F	
HYUNDAI	ELANTRA I	1.5 i.e		63	86	4		199.010	199.511	F	
HYUNDAI	S COUPE (SLC)	1.5 i		62	84	4		199.002	199.605	F	
HYUNDAI	S COUPE (SLC)	1.5 i		65	88	4		199.204	199.605	F	
HYUNDAI	S COUPE (SLC)	1.5 i Turbo		85	116	4		199.104	199.605	F	
HYUNDAI	ELANTRA II Jet (J-2)	1.5 12V		65	88	4		199.704		F	
HYUNDAI	ELANTRA II (J-2)	1.5 12V		65	88	4		199.512	200.009	F	



Stock No: 5054

19.30 \$

Brand	Model	Motorization	Engine	Kw	Hp	Cylinders	Valves	From Date	To Date	Fuel	OEM
HYUNDAI	GALLOPER II	2.5 TD	D4BA	65	88	4	2	01.01.1998		D	23129-42000
HYUNDAI	GALLOPER II	3.0 V6	G6AT	104	141	6	2	01.01.1998		D	
HYUNDAI	GALLOPER II	2.5 TD Intercooler	D4BH	73	99	4	2	01.01.1998		D	
HYUNDAI	GALLOPER II	2.5 TCI D	D4BH	77	105	4	2	01.01.1998		D	
HYUNDAI	GALLOPER II	TD All-wheel Drive	D4BB	63	86	4	2	01.01.1998		D	



Stock No: 5055

Brand	Model	Motorization	Engine	Kw	Hp	Cylinders	Valves	From Date	To Date	Fuel	OEM
HYUNDAI	HD 35										ME-012356



HYUNDAI - KIA
NISSAN

Stock No: 5056

Brand	Model	Motorization	Engine	Kw	Hp	Cylinders	Valves	From Date	To Date	Fuel	OEM
HYUNDAI	ELANTRA										MD377604
											MD338319
											MD376608



Stock No: 5057

Brand	Model	Motorization	Engine	Kw	Hp	Cylinders	Valves	From Date	To Date	Fuel	OEM
HYUNDAI	ELANTRA I (J-1)	1.5 i.e.						199.010	199.511	P	23124-24010
HYUNDAI	EXCEL (X-2)	1.3						198.910	199.501		
HYUNDAI	EXCEL (X-2)	1.6						198.910	199.501		
HYUNDAI	EXCEL (X-2)	1.5 i						198.910	199.501		
HYUNDAI	EXCEL (X-2)	1.5 i						198.910	199.501		
HYUNDAI	EXCEL (X-2)	1.3						198.910	199.501		
HYUNDAI	EXCEL Saloon (X-2)	1.6						199.001	199.501		
HYUNDAI	EXCEL Saloon (X-2)	1.5 i						199.001	199.501		
HYUNDAI	EXCEL Saloon (X-2)	1.5 i						199.001	199.501		
HYUNDAI	EXCEL Saloon (X-2)	1.3						199.001	199.501		
HYUNDAI	EXCEL Saloon (X-2)	1.3						199.212	199.409		
HYUNDAI	S COUPE (SLC)	1.5 i						199.002	199.605		
HYUNDAI	S COUPE (SLC)	1.5 i						199.204	199.605		
HYUNDAI	S COUPE (SLC)	1.5 i Turbo						199.104	199.605		



Stock No: 5058

Brand	Model	Motorization	Engine	Kw	Hp	Cylinders	Valves	From Date	To Date	Fuel	OEM
HYUNDAI	STAREX				100			01.01.2000	01.01.2005		23124-42030



HYUNDAI - KIA
NISSAN

HYUNDAI - KIA
NISSAN

Stock No: 5059

Stock No: 5061

Brand	Model	Motorization	Engine	Kw	Hp	Cylinders	Valves	From Date	To Date	Fuel	OEM
HYUNDAI	ACCENT	1.3 RPI					12				
HYUNDAI	ACCENT	1.5 RPI					16				
HYUNDAI	ELENTRA	1.6 GLS									
HYUNDAI	GETZ	1.4 GLS									

Brand	Model	Motorization	Engine	Kw	Hp	Cylinders	Valves	From Date	To Date	Fuel	OEM
HYUNDAI	STAREX	140BG						01.01.2005	01.01.2008	CRDi	23124-42030



Stock No: 5060

Stock No: 5062

Brand	Model	Motorization	Engine	Kw	Hp	Cylinders	Valves	From Date	To Date	Fuel	OEM
HYUNDAI	ACCENT GETZ	1.5								CRDi	

Brand	Model	Motorization	Engine	Kw	Hp	Cylinders	Valves	From Date	To Date	Fuel	OEM
HYUNDAI	TRAJET (FO)	2.0 CRDi		83	113	4		200.104		D	23124-27000
HYUNDAI	SANTA FE I (SM)	2.0 CRDi 4x4		83	113	4		200.104	200.603	D	23124-27100
HYUNDAI	SANTA FE I (SM)	2.0 CRDi		83	113	4		200.108	200.603	D	23124-27300
HYUNDAI	EXCEL II (LC)	1.5 CRDi		60	82	3		200.204		D	23124-27400
HYUNDAI	TUCSON (JM)	2.0 CRDi		83	113	4		200.408		D	
HYUNDAI	TUCSON (JM)	2.0 CRDi All-wheel Drive		83	113	4		200.408		D	
HYUNDAI	ACCENT Saloon (LC)	1.5 CRDi		60	82	4		200.201	200.511	D	
KIA	CARENS MK II (FJ)	2.0 CRDi		83	113	4		200.207		D	
KIA	LOTZE (MG)	2.0 CRDi		103	140	4		200.604		D	
KIA	SPORTAGE (JE)	2.0 CRDi 4WD		103	140	4		200.601		D	



Stock No: 3033

Brand	Model	Motorization	Engine	Kw	Hp	Cylinders	Valves	From Date	To Date	Fuel	OEM
NISSAN	NAVARA (D21)	TD25		74	101	4		198.710	199.203	D	1230300601
NISSAN	NAVARA (D21)	TD27		76	103	4		198.710	199.412	D	



Stock No: 2095

Brand	Model	Motorization	Engine	Kw	Hp	Cylinders	Valves	From Date	To Date	Fuel	OEM
NISSAN	Kubistar	1.5 DCI	CG10DE	72	98	4	4	01.08.2003	-	D	1230300DAU
NISSAN	Micra	1.0 15V	CR12DE	79	107	4	4	01.01.2003	-	P	
NISSAN	Micra	1.2 15V		74	100	4	2	01.01.2003	-	P	



Stock No: 5063

Brand	Model	Motorization	Engine	Kw	Hp	Cylinders	Valves	From Date	To Date	Fuel	OEM
KIA	SPORTAGE (K00)	2.0 TD 4WD		81	83	4		199.710	200.308	D	2312444002
KIA	SORENTO (JC)	2.5 CRDi		103	140	4		200.208		D	
KIA	SORENTO (JC)	CRDi		125	170	4		200.612		D	
KIA	SPORTAGE (JE)	2.0 CRDi		83	113	4		200.502		D	



TOYOTA

HYUNDAI - KIA
NISSAN

Stock No: 2092

Brand	Model	Motorization	Engine	Kw	Hp	Cylinders	Valves	From Date	To Date	Fuel	OEM
NISSAN	Micra	1.5 DCI	K9K 722	60	82	4	2	01.01.2003	-	D	1230300QAY
NISSAN	Note	1.5 DCI	K9K 704	48	65	4	2	01.01.2008	-	F	
NISSAN	Qashqai	1.5 DCI	K9K 704	48	65	4	2	01.04.2008	-	F	



Stock No: 5064

Brand	Model	Motorization	Engine	Kw	Hp	Cylinders	Valves	From Date	To Date	Fuel	OEM
KIA	HI-BESTA -PREGIO-BONGO	2500cc									23129-40901



Stock No: 5065

Brand	Model	Motorization	Engine	Kw	Hp	Cylinders	Valves	From Date	To Date	Fuel	OEM
NISSAN	VANETTA CARGO	23									1230370007



Stock No: 5066

Brand	Model	Motorization	Engine	Kw	Hp	Cylinders	Valves	From Date	To Date	Fuel	OEM
NISSAN	PRIMERA SR 20	2000cc									123032F200

Stock No: 5067

Brand	Model	Motorization	Engine	Kw	Hp	Cylinders	Valves	From Date	To Date	Fuel	OEM
TOYOTA	HIACE II Wagon (H20)	2.4 D						198405-198908		D	13408-54090
TOYOTA	HIACE II Wagon (H20)	2.4 D 4WD						198.701-198.801		D	
TOYOTA	TACOMA II Pickup	2.4 D						199201 / -		D	
TOYOTA	TACOMA II Pickup	2.4 D 4WD						199401 / -		D	
TOYOTA	TACOMA II Pickup	2.4 D						199503 / -		D	
TOYOTA	TACOMA II Pickup	2.4 D						198808 / -		D	
TOYOTA	TACOMA II Pickup	2.4 D 4WD						198808 / -		D	
TOYOTA	TACOMA II Pickup	2.4 D						199807-200201		D	
TOYOTA	TACOMA II Pickup	2.4 D 4WD						198.401		D	
TOYOTA	HIACE III Wagon (H50)	2.4 D						198.908-199.508		D	
TOYOTA	HIACE III Wagon (H50)	2.4 D						198.510-199.508		D	
TOYOTA	HIACE III Wagon (H50)	2.4 D						198.908-199.508		D	
TOYOTA	HIACE IV Wagon	2.4 D						199505 / -		D	
TOYOTA	HIACE IV Wagon	2.4 D						199907 / -		D	
TOYOTA	HIACE II (H20)	2.4 D						198.405-198.911		D	
TOYOTA	HIACE III (H50)	2.4 D						199002-199508		D	
TOYOTA	HIACE III (H50)	2.4 D						198.908-199.508		D	
TOYOTA	HIACE III (H50)	2.4 D						198.909-199.508		D	
TOYOTA	HIACE IV Box	2.4 D						199505 / -		D	
TOYOTA	HIACE IV Box	2.4 D						199.509-200.108		D	



Stock No: 5068

Brand	Model	Motorization	Engine	Kw	Hp	Cylinders	Valves	From Date	To Date	Fuel	OEM
TOYOTA	AE 92	1.5 D									13470-16050
											13470-16090



TOYOTA

HONDA

Stock No: 5069

Stock No: 5072

Brand	Model	Motorization	Engine	Kw	Hp	Cylinders	Valves	From Date	To Date	Fuel	DEM
TOYOTA	AE 101	1.3 D									13408-11012 13470-11030

Brand	Model	Motorization	Engine	Kw	Hp	Cylinders	Valves	From Date	To Date	Fuel	DEM
HONDA CIVIC	CIVIC	1.6						1995	22.6.1905		135-PEA-007



Stock No: 5070

Stock No: 5073

Brand	Model	Motorization	Engine	Kw	Hp	Cylinders	Valves	From Date	To Date	Fuel	DEM
TOYOTA	CAMRY							01.01.2001			13408-74031
TOYOTA	SOLARA							01.01.2000			13408-74031
TOYOTA	CELICA							01.01.1999			13408-74041
TOYOTA	TRUCK							01.01.1998			
TOYOTA	CAMRY							01.01.1997			
TOYOTA	CELICA							01.01.1996			

Brand	Model	Motorization	Engine	Kw	Hp	Cylinders	Valves	From Date	To Date	Fuel	DEM
HONDA	CIVIC							01.01.2000	01.01.2005		13611-P01-000



Stock No: 5071

Stock No: 5074

Brand	Model	Motorization	Engine	Kw	Hp	Cylinders	Valves	From Date	To Date	Fuel	DEM
TOYOTA	Yaris Vitz (P1)	1.0 16V						199904	- /	P	1340700J010
TOYOTA	Yaris Vitz (P1)	1.3 16V						199904	- /	P	
TOYOTA	Yaris Vitz (P1)	1.3						199904	- /	P	
TOYOTA	Yaris Vitz (P1)	1.0 16V						199904	- /	P	
TOYOTA	Yaris Verso	1.3						199904	- /	P	
TOYOTA	Yaris Verso	1.3						199904	- /	P	
TOYOTA	Yaris Vitz (P9)	1.3 VVT-i						199904	- /	P	

Brand	Model	Motorization	Engine	Kw	Hp	Cylinders	Valves	From Date	To Date	Fuel	DEM
HONDA	CIVIC	1.6 CC						01.01.2000	01.01.2005		13611-P01-000



Stock No: 5075

Brand	Model	Motorization	Engine	Kw	Hp	Cylinders	Valves	From Date	To Date	Fuel	DEM
HONDA	JAZZ	1.4 CC						03.05.2002	01.01.2007		13610-PWC-013



BMW

Stock No: 5076

Brand	Model	Motorization	Engine	Kw	Hp	Cylinders	Valves	From Date	To Date	Fuel	OEM
BMW	7 Saloon (E65, E66)	730 d		160	218	6	4	200.210		D	
BMW	7 Saloon (E65, E66)	730 Ld		170	231	6	4	200.507		D	
BMW	3 Coupe (E45)	330 Cd		150	204	6	4	200.303		D	
BMW	3 Saloon (E46)	330 d		150	204	6	4	200.303	200.502	D	11237793593
BMW	3 Saloon (E46)	330 xd		150	204	6	4	200.303	200.502	D	11237793593
BMW	3 Touring (E45)	330 d		150	204	6	4	200.303	200.502	D	
BMW	3 Touring (E45)	330 xd		150	204	6	4	200.303	200.502	D	
BMW	X5 (E53)	3.0 d		160	218	6	4	200.312		D	
BMW	5 Touring (E51)	530e		160	218	6	4	200.406		D	
BMW	5 Touring (E51)	525e		130	177	6	4	200.406		D	
BMW	5 Touring (E51)	535e		200	272	6	4	200.409		D	
BMW	5 Touring (E51)	530e		170	231	6	4	200.507		D	
BMW	5 Touring (E51)	530xd		170	231	6	4	200.507		D	
BMW	5 Touring (E51)	525e		120	163	6	4	200.412		D	
BMW	5 Touring (E51)	525e		145	197	6	4	200.701		D	
BMW	5 Touring (E51)	530e		173	235	6	4	200.701		D	
BMW	5 Touring (E51)	530xd		173	235	6	4	200.701		D	
BMW	5 Touring (E51)	535e		210	286	6	4	200.701		D	
BMW	5 Touring (E51)	525xd		145	197	6	4	200.701		D	
BMW	5 Saloon (E60)	525e		130	177	6	4	200.406		D	
BMW	5 Saloon (E60)	535e		200	272	6	4	200.409		D	
BMW	5 Saloon (E60)	530e		170	231	6	4	200.507		D	
BMW	5 Saloon (E60)	530xd		170	231	6	4	200.507		D	
BMW	5 Saloon (E60)	525e		120	163	6	4	200.412		D	
BMW	5 Saloon (E60)	535e		210	286	6	4	200.701		D	
BMW	5 Saloon (E60)	525e		145	197	6	4	200.701		D	
BMW	5 Saloon (E60)	530e		173	235	6	4	200.701		D	
BMW	5 Saloon (E60)	530xd		173	235	6	4	200.701		D	
BMW	3 Saloon (E90)	330e		170	231	6	4	200.508		D	
BMW	3 Saloon (E90)	330xd		170	231	6	4	200.509		D	
BMW	3 Saloon (E90)	335e		210	286	6	4	200.609		D	
BMW	3 Saloon (E90)	325e		145	197	6	4	200.609		D	
BMW	3 Touring (E91)	330e		170	231	6	4	200.508		D	
BMW	3 Touring (E91)	330xd		170	231	6	4	200.509		D	
BMW	3 Touring (E91)	335e		210	286	6	4	200.609		D	
BMW	3 Touring (E91)	325e		145	197	6	4	200.609		D	
BMW	X3 (E83)	3.0 d		160	218	6	4	200.401		D	
BMW	X3 (E83)	3.0 sd		210	286	6	4	200.609		D	
BMW	3 Convertible (E46)	330 Cd		150	204	6	4	200.508		D	
BMW	3 Coupe (E92)	335e		210	286	6	4	200.609		D	
BMW	3 Coupe (E92)	330e		170	231	6	4	200.609		D	
BMW	3 Coupe (E92)	325e		145	197	6	4	200.703		D	
BMW	3 Convertible (E93)	330e		170	231	6	4	200.703		D	
BMW	3 Convertible (E93)	325e		145	197	6	4	200.703		D	
BMW	X5 (E70)	3.0 d		173	235	6	4	200.702		D	
BMW	X5 (E70)	3.0 sd		210	286	6	4	200.709		D	
BMW	6 (E63)	635e		210	286	6	4	200.707		D	
BMW	6 Convertible (E64)	635e		210	286	6	4	200.707		D	
BMW	X6 (E71, E72)	30d		173	235	6	4	200.805		D	
BMW	X6 (E71, E72)	35d		210	286	6	4	200.805		D	



BMW

Stock No: 5077

Brand	Model	Motorization	Engine	Kw	Hp	Cylinders	Valves	From Date	To Date	Fuel	OEM
BMW	3 Saloon (E46)	320 d		100	136	4		199.804	200.109	D	11232247565
BMW	3 Saloon (E46)	318 d		85	116	4		200.109	200.303	D	
BMW	3 Touring (E46)	320 d		100	136	4		200.003	200.109	D	
BMW	3 Touring (E46)	318 d		85	116	4		200.203	200.502	D	
BMW	5 Saloon (E39)	520 d		100	136	4		200.002	200.306	D	
BMW	5 Touring (E39)	520 d		100	136	4		200.002	200.309	D	



Stock No: 5078

Brand	Model	Motorization	Engine	Kw	Hp	Cylinders	Valves	From Date	To Date	Fuel	OEM
BMW	3 Compact (E46)	320 td		110	150	4		200.109	200.502	D	11237787304
BMW	3 Compact (E46)	318 td		85	115	4		200.303	200.502	D	11237790921
BMW	3 Saloon (E46)	320 d		110	150	4		200.109	200.502	D	11237793882
BMW	3 Saloon (E46)	318 d		85	115	4		200.303	200.502	D	11237801977
BMW	3 Touring (E46)	320 d		110	150	4		200.109	200.502	D	11237805696
BMW	3 Touring (E45)	318 d		85	115	4		200.303	200.502	D	
BMW	3 Coupe (E46)	320 Cd		110	150	4		200.311		D	
BMW	1 (E81, E87)	118d		90	122	4		200.409		D	
BMW	1 (E81, E87)	120d		120	163	4		200.409		D	
BMW	X3 (E83)	2.0 d		110	150	4		200.410		D	
BMW	3 Convertible (E46)	320 Cd		110	150	4		200.502		D	
BMW	3 Saloon (E90)	320d		120	163	4		200.501		D	
BMW	3 Saloon (E90)	318e		90	122	4		200.509		D	
BMW	3 Saloon (E90)	320e		110	150	4		200.509		D	
BMW	3 Touring (E91)	320e		120	163	4		200.509		D	
BMW	5 Saloon (E60)	520e		120	163	4		200.507		D	
BMW	5 Touring (E51)	520e		120	163	4		200.507		D	
BMW	3 Coupe (E92)	320e		130	177	4		200.703		D	



BMC - FIAT

Stock No: 3021

Brand	Model	Motorization	Engine	Kw	Hp	Cylinders	Valves	From Date	To Date	Fuel	DEM
BMC	TM 30 (E. M.)	TEK KAYIŞ									M4E9001



Stock No: 3022

Brand	Model	Motorization	Engine	Kw	Hp	Cylinders	Valves	From Date	To Date	Fuel	DEM
BMC	TM 30 (Y. M.)	ÇİFT KAYIŞ									2M59501



Stock No: 1030

Brand	Model	Motorization	Engine	Kw	Hp	Cylinders	Valves	From Date	To Date	Fuel	DEM
FIAT	SAMIN - DOGAN	1600									7653405



FIAT - FORD

Stock No: 1060

Brand	Model	Motorization	Engine	Kw	Hp	Cylinders	Valves	From Date	To Date	Fuel	DEM
FIAT	131	1300									85015919

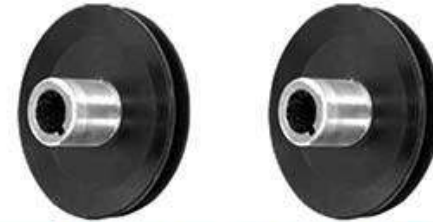

Stock No: 1083

Brand	Model	Motorization	Engine	Kw	Hp	Cylinders	Valves	From Date	To Date	Fuel	DEM
											711M6312AA



Stock No: 1024

Brand	Model	Motorization	Engine	Kw	Hp	Cylinders	Valves	From Date	To Date	Fuel	DEM
POLANEZ											



Stock No: 3004

Brand	Model	Motorization	Engine	Kw	Hp	Cylinders	Valves	From Date	To Date	Fuel	DEM
FORD	2.4 - 2.5										

Since 1977



2016 CATALOG